

Montageanleitung / Assembly instructions
Instructions de montage
Istruzioni di montaggio

Seitenverkleidung Stahl komplett montieren

Mounting complete steel side cladding

Installer l'habillage latéral en acier complet

Montaggio rivestimento laterale in acciaio completo



AUSTROFLAMM

www.austroflamm.com

Originalbetriebsanleitung

15/01/2025

Version:

IMPRESSUM

Eigentümer und Herausgeber

AUSTROFLAMM GMBH

Austroflamm-Platz 1

A- 4631 Krenglbach

Tel: +43 (0) 7249 / 46 443

www.austroflamm.com

info@austroflamm.com

Redaktion: Olivera Stojanovic

Abbildungen: Konstruktion

Text: Technische Abteilung (Austroflamm)

Copyright

Alle Rechte vorbehalten. Der Inhalt dieser Anleitung darf nur mit Genehmigung des Herausgebers vervielfältigt oder verbreitet werden! Druck-, Rechtschreib- und Satzfehler vorbehalten.

Die Informationen in diesem Dokument können ohne vorherige Ankündigung geändert werden und stellen keine Verpflichtung seitens der Austroflamm GmbH dar. Für eventuelle Fehler in diesem Dokument übernimmt die Austroflamm GmbH keine Haftung.

Inhaltsverzeichnis

Deutsch.....	4
English	9
Français.....	14
Italiano	19

1 Allgemeines

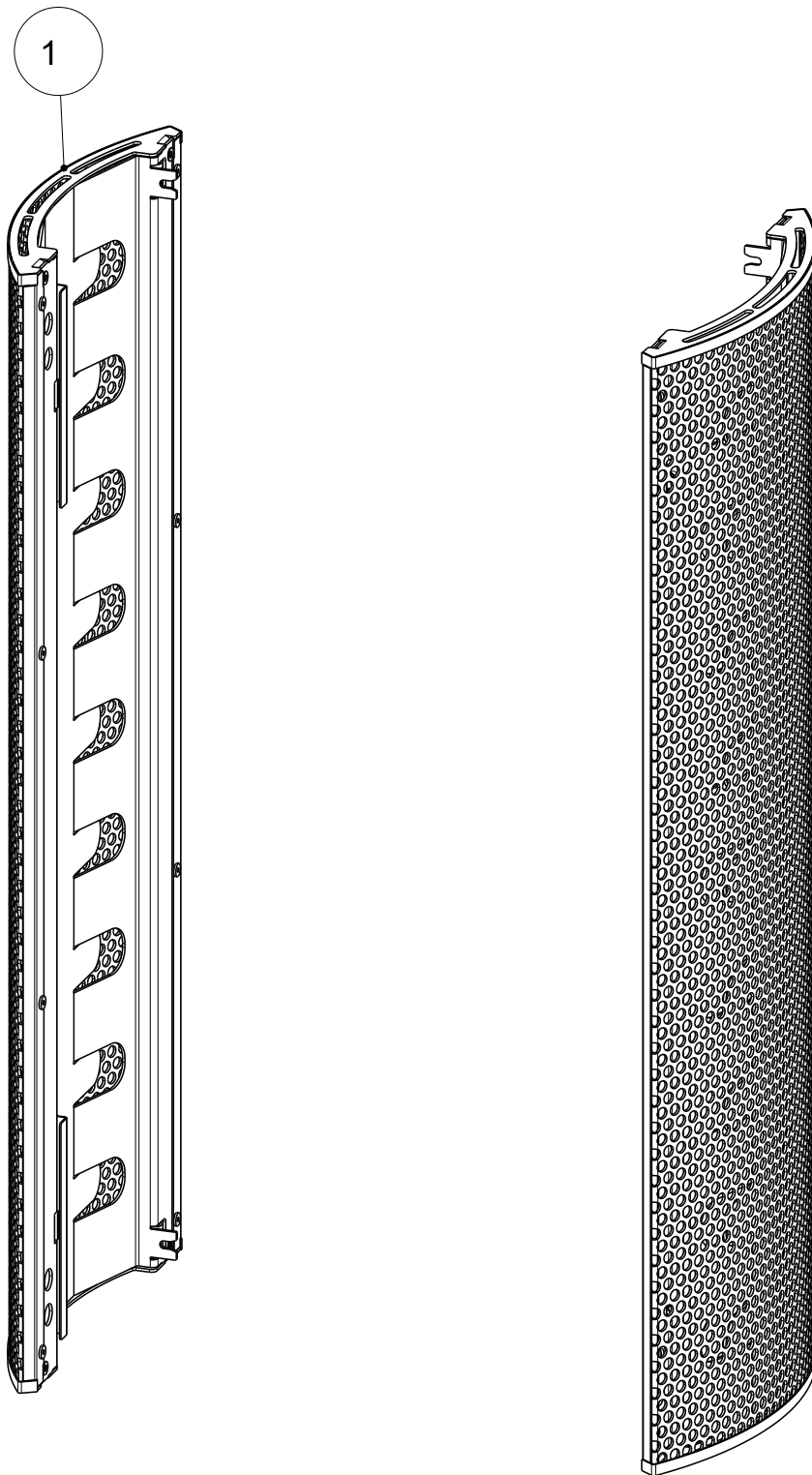

Pos. Nr.	Anzahl	Artikel	Artikel-Nr.
1	2	Seitenverkleidung Stahl montiert	732295

2 Seitenverkleidung Stahl komplett montieren



Abb. 1: Tankdeckel öffnen

- 1) Tankdeckel öffnen.

WARNUNG

Quetschgefahr

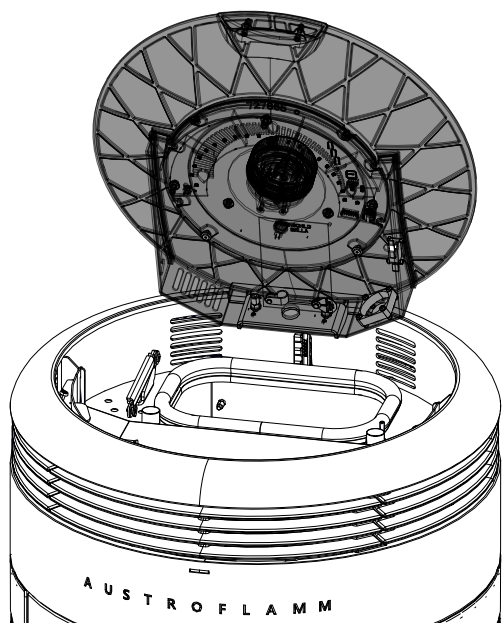
Achten Sie darauf, dass der Tankdeckel zufallen kann.



Abb. 2: Schraube lösen

- 2) Um die seitliche rechte Verkleidung zu demontieren, muss diese Schraube im Pellettank gelöst werden.
- 3) Um die seitliche linke Verkleidung zu demontieren, muss diese Schraube im Pellettank auf der anderen Seite gelöst werden.

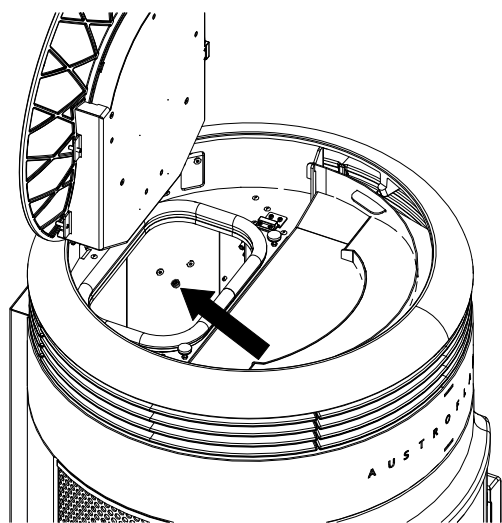

Abb. 3: Seitenverkleidung abnehmen

4) Seitenverkleidungen abnehmen.

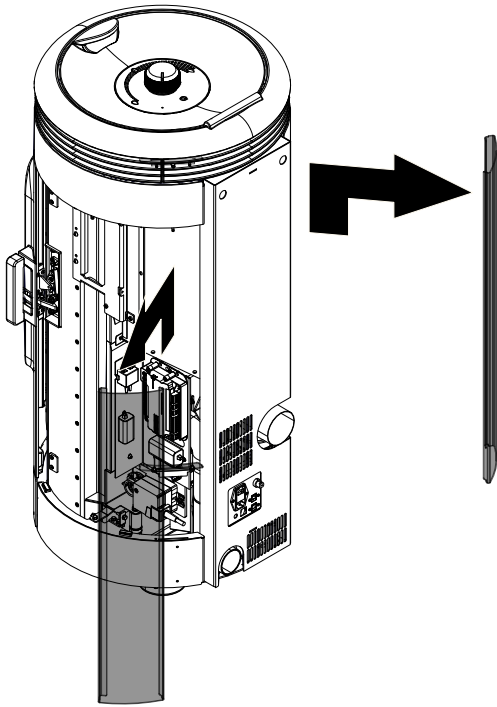

Abb. 4: Andrückbleche

5) Die Stahl- oder Keramikverkleidung an den zwei Andrückblechen anbringen.

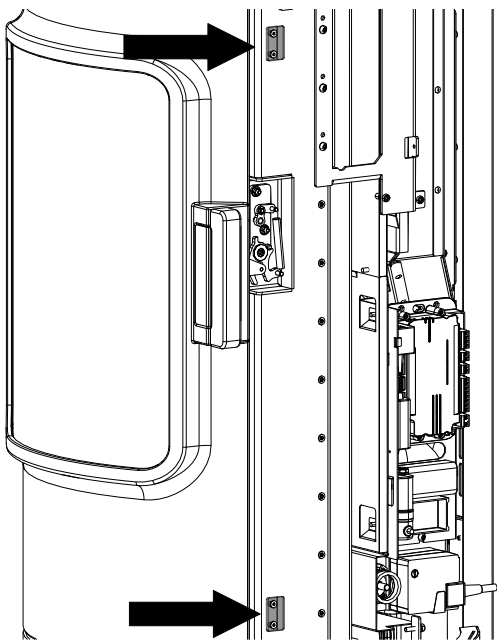
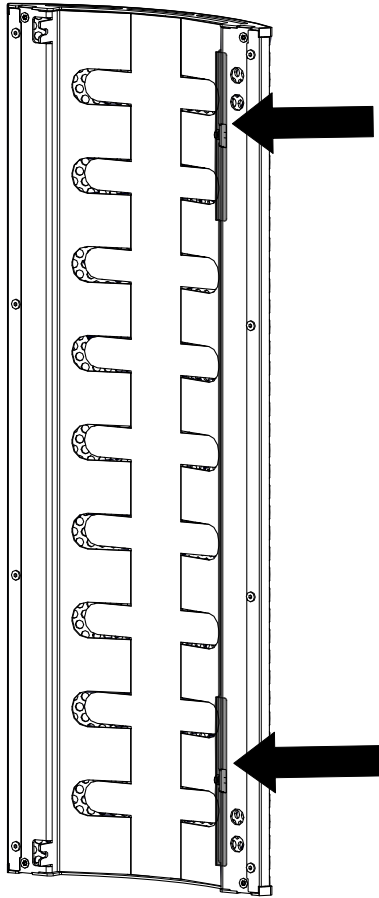

- 6) Die Stahl- oder Keramikverkleidung wird mit den Blechen an den Andrückblechen angebracht.

Abb. 5: Stahl-/Keramikverkleidung anbringen



Abb. 6: oben



Abb. 7: unten

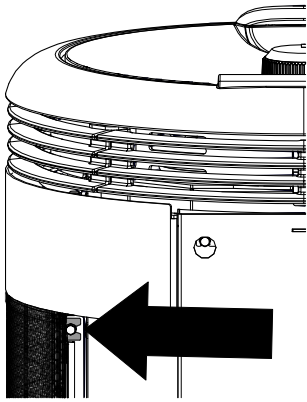

Abb. 8: Stahl-/Keramik und Seitenverkleidung montiert

Die Stahl- oder Keramikverkleidung hinten am Ofen an zwei Stellen befestigen.

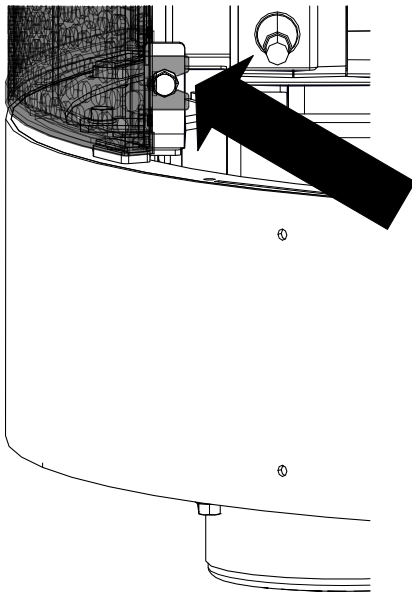
7) Die Seitenverkleidungen wieder anbringen und befestigen.

1 General

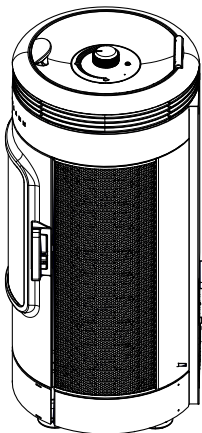
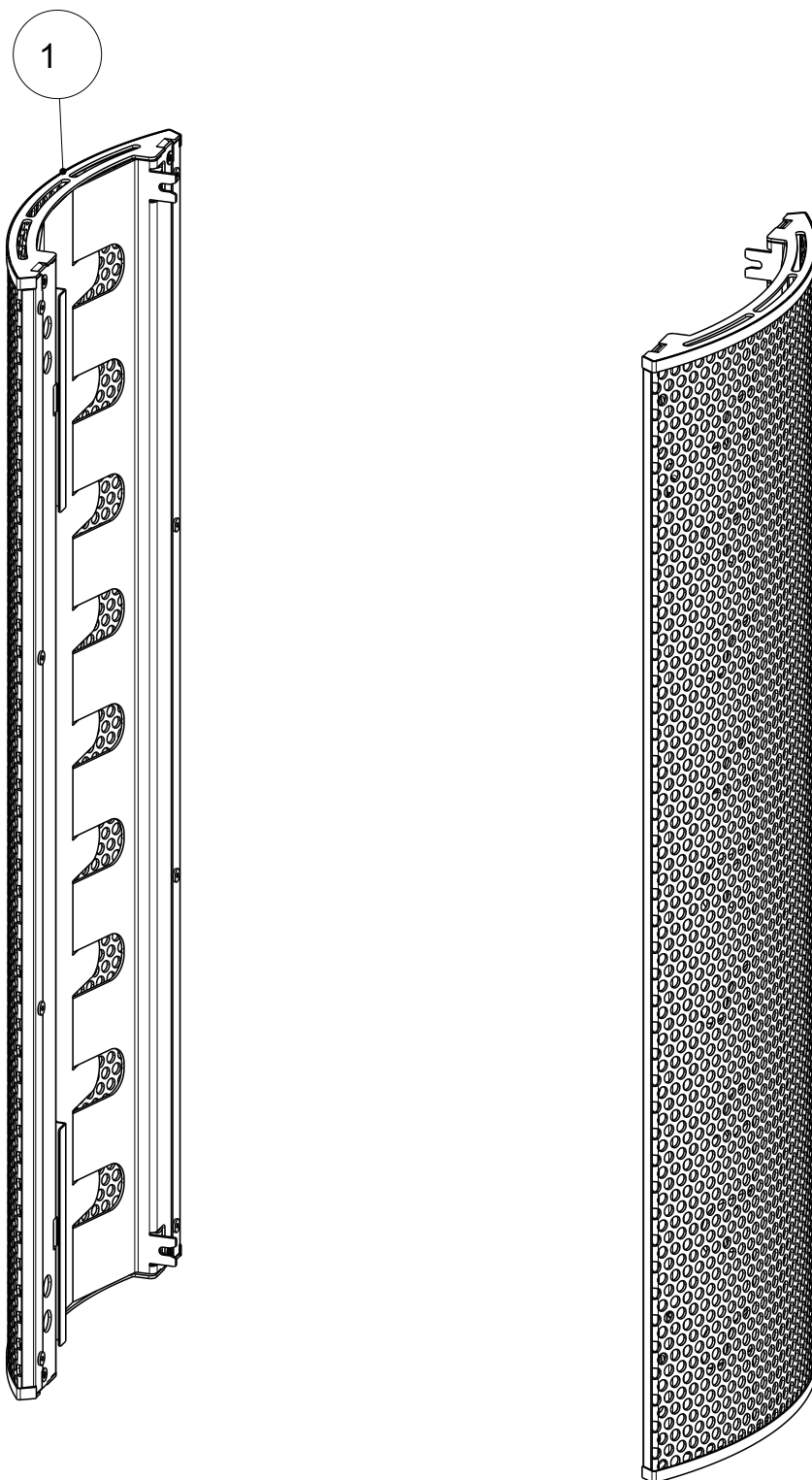

Item no.	Quantity	Article	Article no.
1	2	Mounting steel side cladding	732295

2 Mounting complete steel side cladding

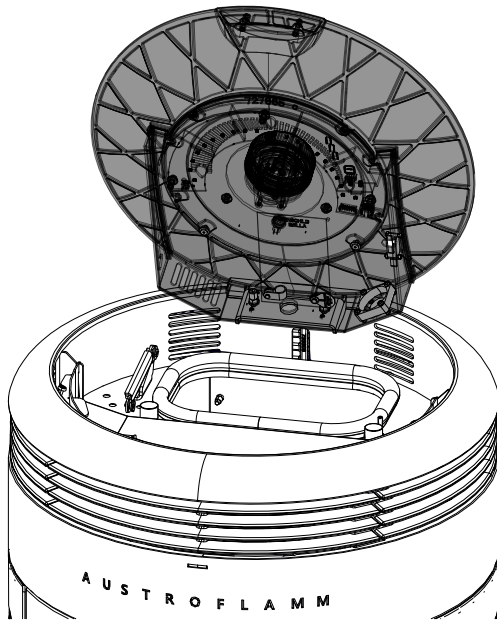

Fig. 1: Opening the hopper lid

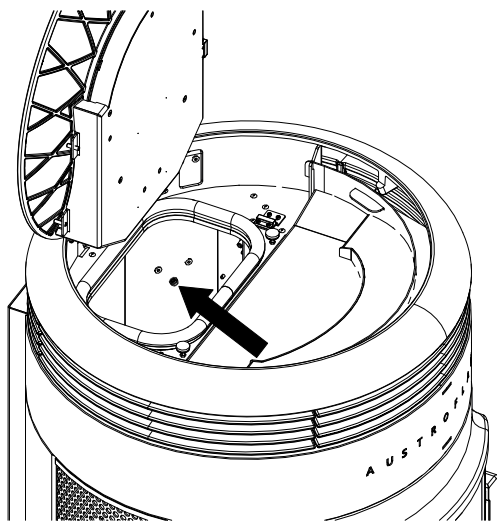

Fig. 2: Undoing the screw

1) Open hopper lid.

WARNING

Risk of crushing injury

Be aware that the hopper lid may fall shut.

- 2) To detach the right-hand side cladding, this screw in the pellet hopper needs to be undone.
- 3) To detach the left-hand side cladding, this screw in the pellet hopper needs to be undone on the other side.

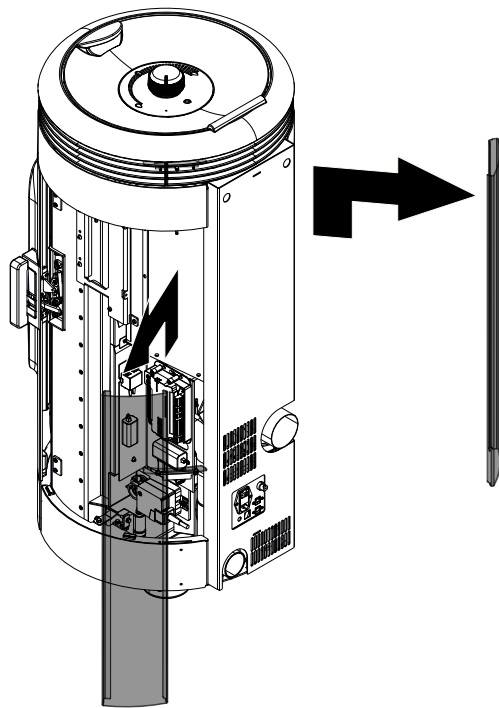

Fig. 3: Detaching the side cladding

4) Detach side cladding.

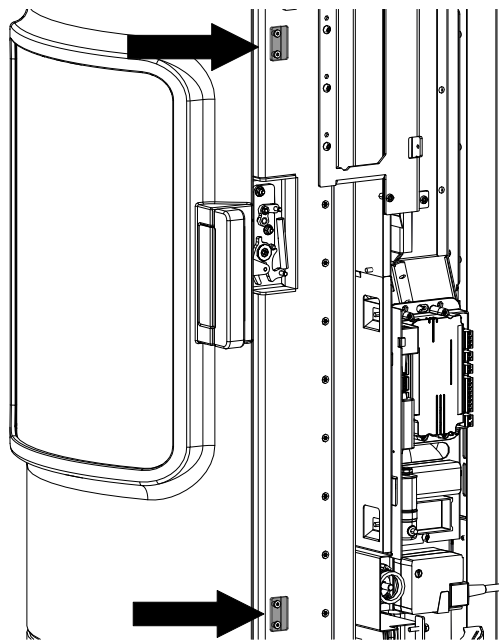
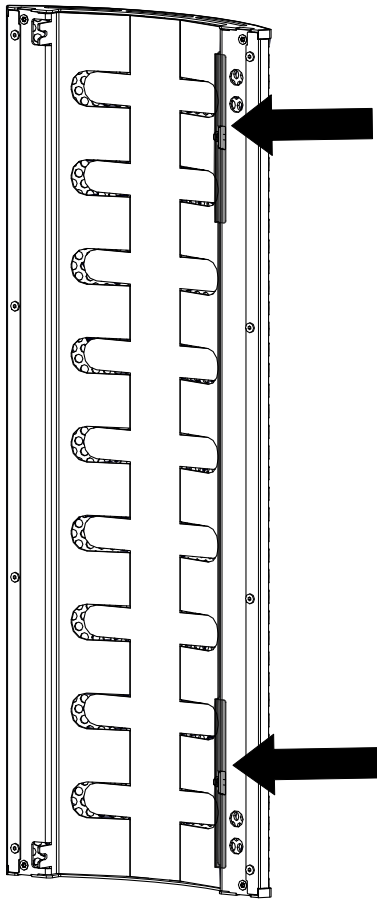

Fig. 4: Pressure plates

5) Attach the steel- or ceramic cladding to the two pressure plates.



- 6) The sheets are used to attach the steel- or ceramic cladding to the pressure plates.

Fig. 5: Attaching the steel-/ceramic cladding

Fasten the steel- or ceramic cladding to the rear of the stove in two places.

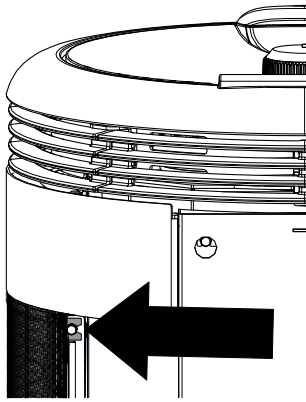

Fig. 6: top

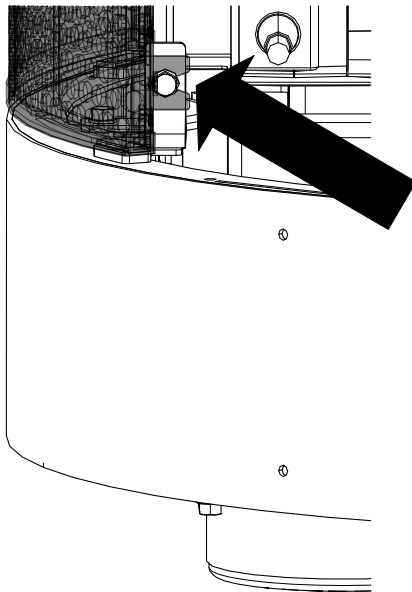

Fig. 7: below

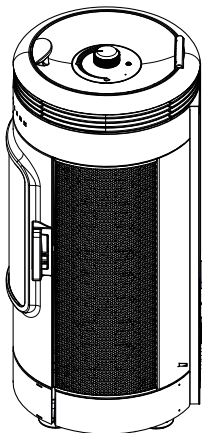
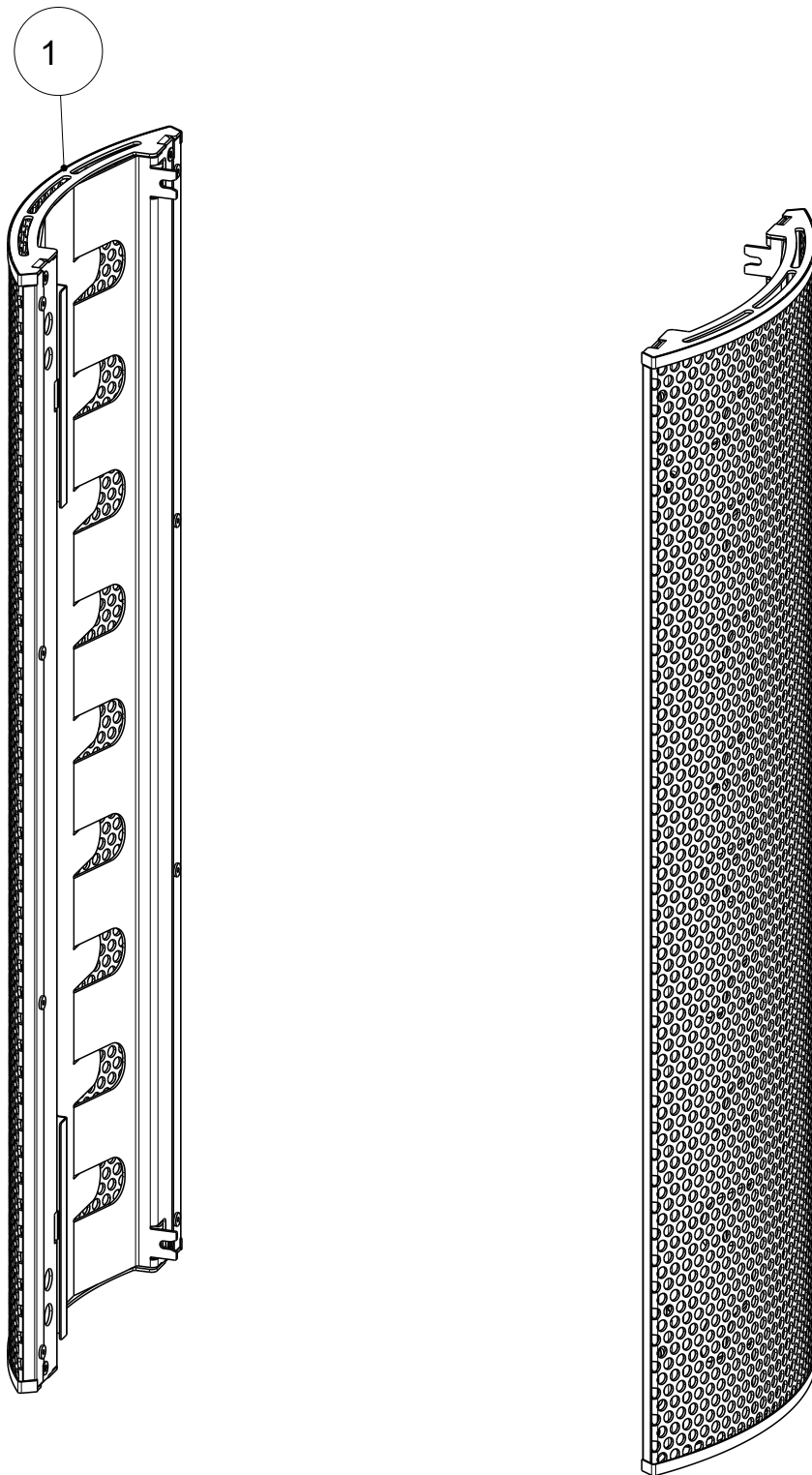

Fig. 8: Steel-/ceramic and side cladding installed

7) Reattach and refasten the side cladding.

1 Généralités



Pos. n°	Quantité	Article	Article n°
1	2	Installer l'habillage latéral en acier	732295

2 Installer l'habillage latéral en acier complet

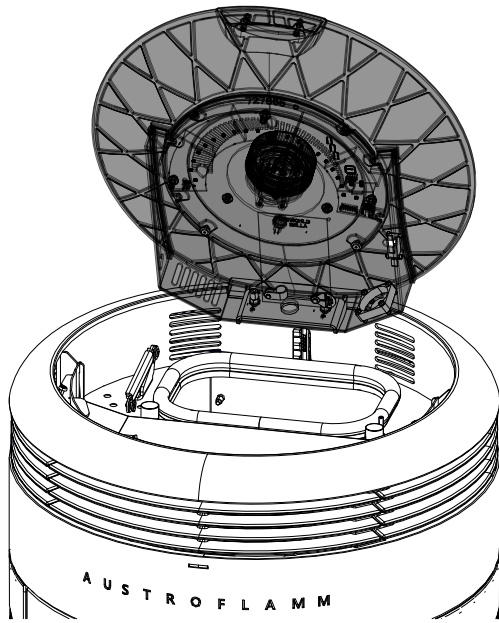

Fig. 1: Ouvrir le couvercle du réservoir

- 1) Ouvrir le couvercle du réservoir.

AVERTISSEMENT

Risque d'écrasement

Faites attention : le couvercle du réservoir peut retomber.

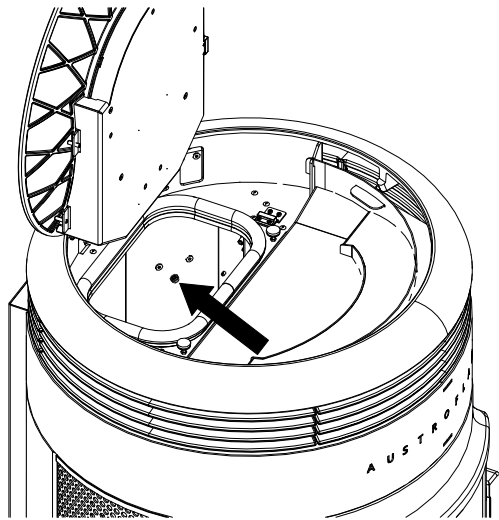

Fig. 2: Dévisser la vis

- 2) Pour démonter l'habillage latéral droit, dévisser dans le réservoir à pellets la vis indiquée par la flèche.
- 3) Pour démonter l'habillage latéral gauche, dévisser la vis opposée dans le réservoir à pellets.

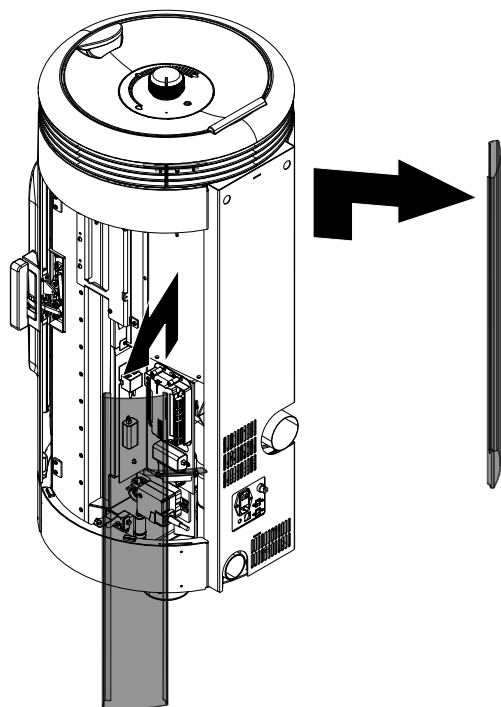

Fig. 3: Enlever l'habillage latéral

4) Enlever les habillages latéraux.

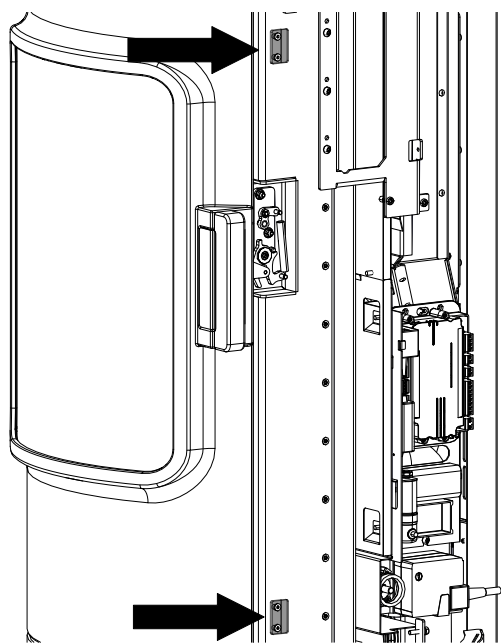
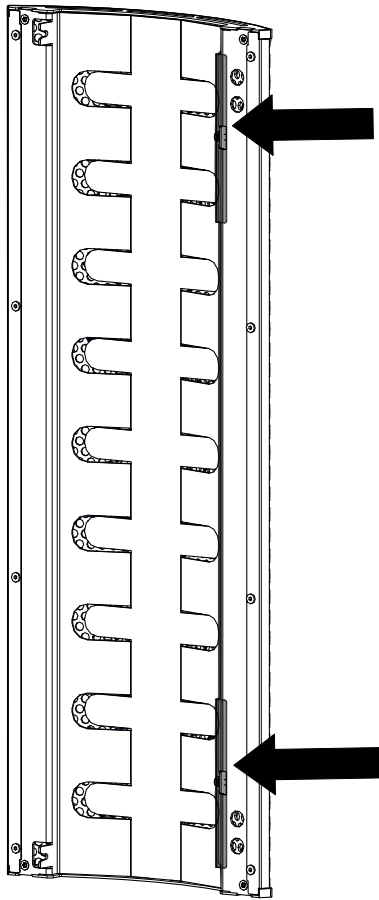

Fig. 4: Plaques d'appui

5) Poser l'habillage en acier ou en céramique sur les deux plaques d'appui.



- 6) L'habillage en acier ou en céramique se place sur les plaques d'appui au niveau de ses cornières métalliques.

Fig. 5: Poser l'habillage en acier/céramique

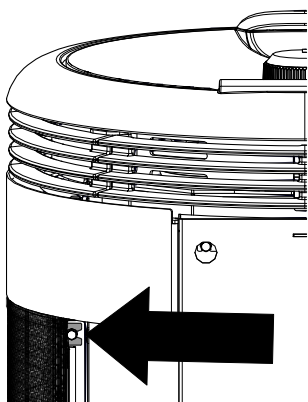

Fig. 6: en haut

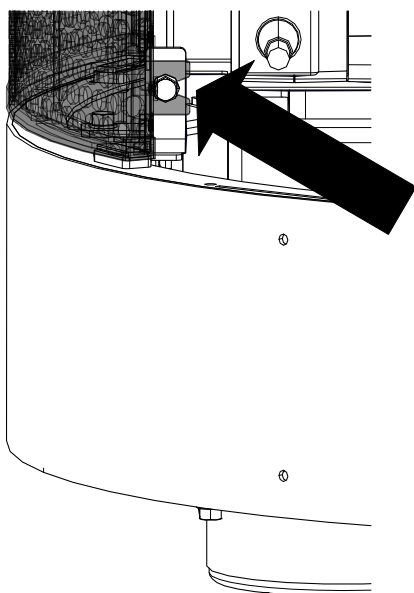

Fig. 7: en bas

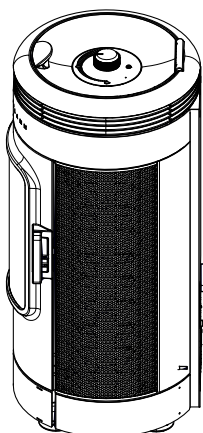
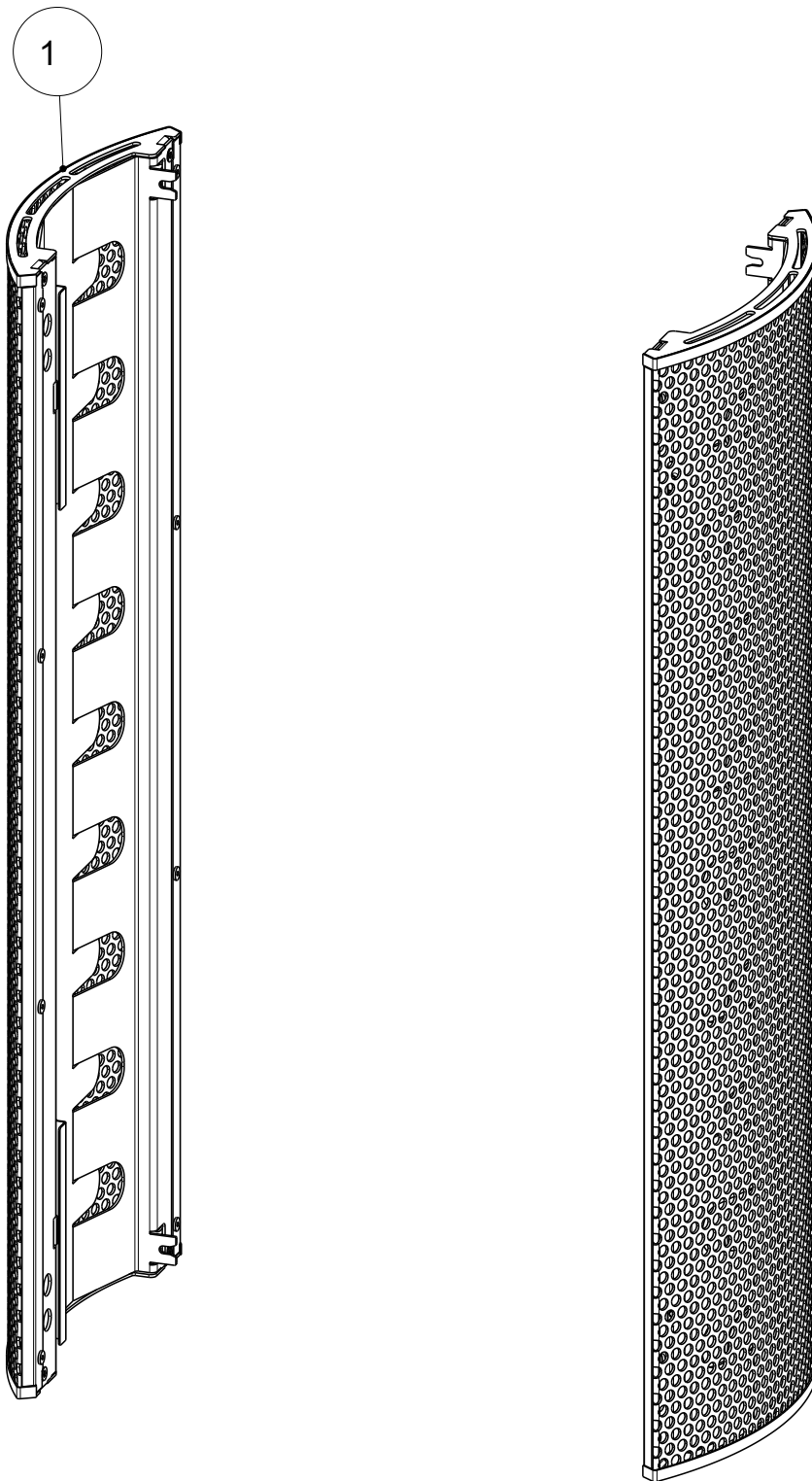

Fig. 8: Habillage en acier/céramique et habillage latéral en place

Fixer l'habillage en acier ou en céramique au dos du poêle, aux deux points indiqués.

7) Remettre les habillages latéraux et les fixer.

1 Generalità



N. pos.	Q.tà	Articolo	N. art.
1	2	Montaggio rivestimento laterale in acciaio	732295

2 Montaggio rivestimento laterale in acciaio completo

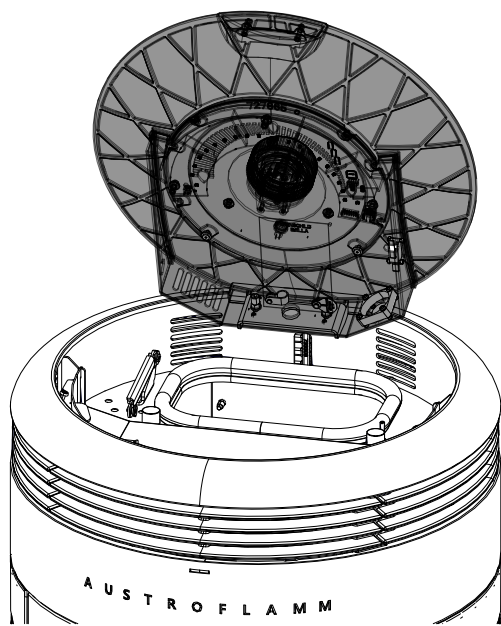

Fig. 1: Apertura del coperchio del serbatoio

1) Aprire il coperchio del serbatoio.

AVVISO

Pericolo di schiacciamento

Assicurarsi che il coperchio del serbatoio possa chiudersi.

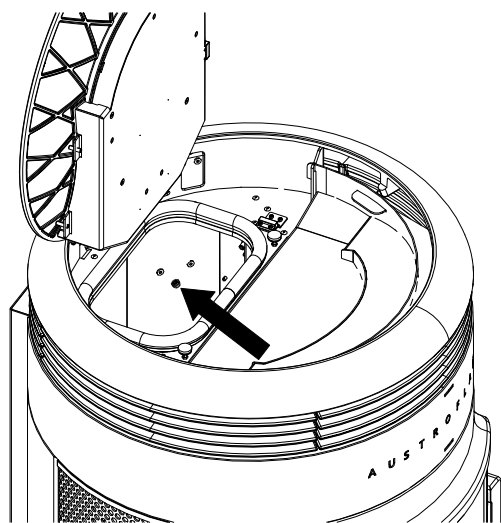

Fig. 2: Svitamento delle viti

- 2) Per rimuovere il rivestimento laterale di destra, occorre allentare questa vite del serbatoio del pellet.
- 3) Per rimuovere il rivestimento laterale di sinistra, occorre allentare questa vite del serbatoio del pellet sull'altro lato.

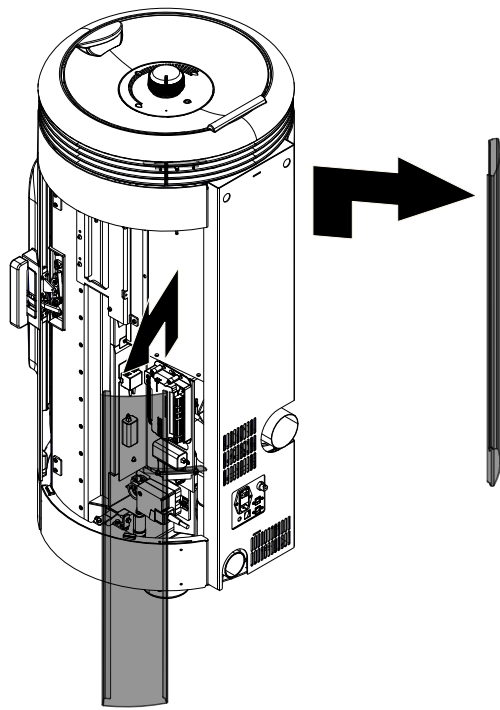

Fig. 3: Rimozione del rivestimento laterale

4) Rimuovere i rivestimenti laterali.

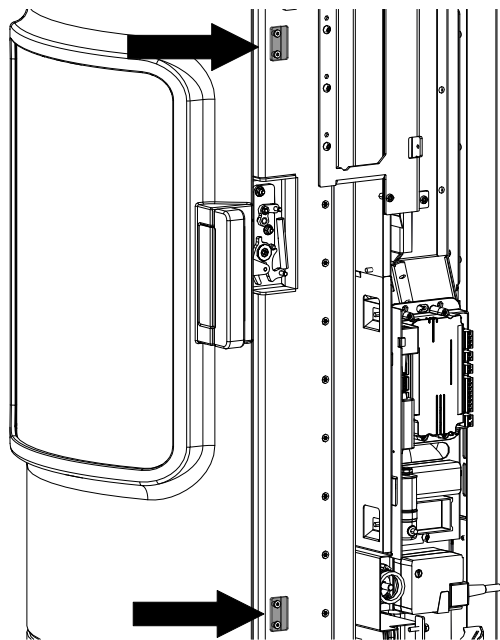
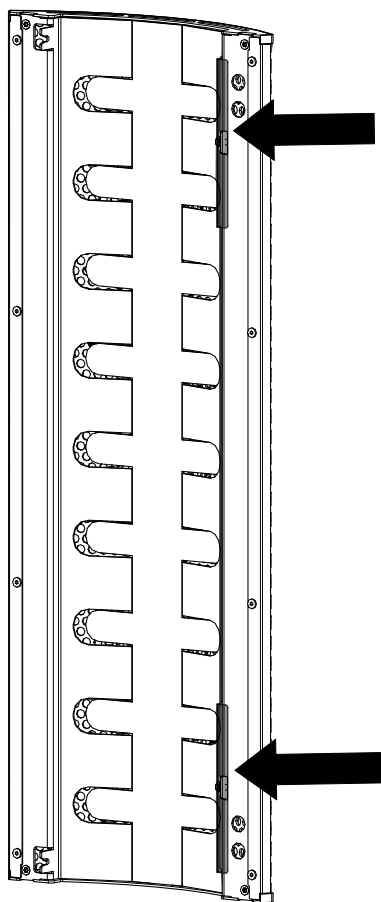

Fig. 4: Piastre di pressione

5) Fissare il cappotto in acciaio o in ceramica alle due piastre di pressione.



- 6) Il cappotto in acciaio o in ceramica viene fissato alle piastre di pressione con le lamiere.

Fig. 5: Collocazione del cappotto in acciaio o in ceramica

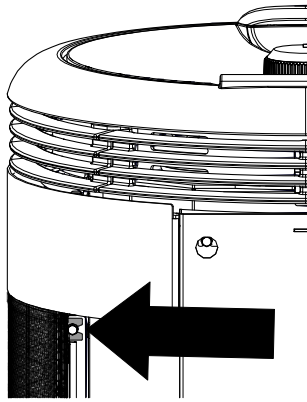

Fig. 6: superiore

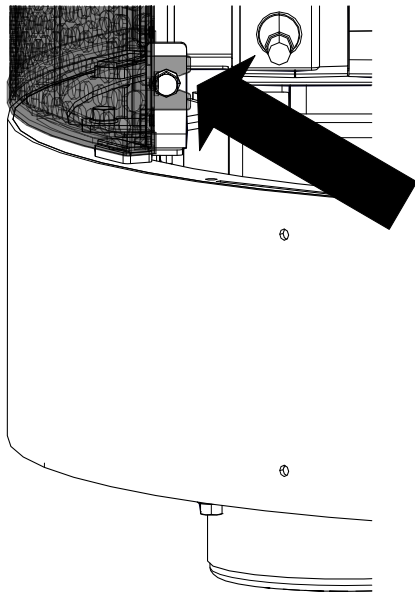

Fig. 7: inferiore

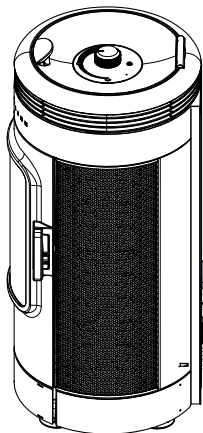

Fig. 8: Cappotto in acciaio o in ceramica e rivestimento laterale montati

Fissare il cappotto in acciaio o in ceramica sul retro della stufa in due punti.

7) Ricollocare e fissare i rivestimenti laterali.

AUSTROFLAMM GMBH
Austroflamm-Platz 1
A- 4631 Krenglbach

Tel: +43 (0) 7249 / 46 443
www.austroflamm.com
info@austroflamm.com

815003-29 - 945201

