

Montageanleitung / Assembly instructions
Instructions de montage
Istruzioni di montaggio

KV Mantel montieren

Mounting the CV cladding
Installer le kit de convection
Installazione del cappotto KV



AUSTROFLAMM

www.austroflamm.com

Originalbetriebsanleitung
25/02/2025

Version: 1.0

IMPRESSUM

Eigentümer und Herausgeber

AUSTROFLAMM GMBH
Austroflamm-Platz 1
A- 4631 Krenglbach
Tel: +43 (0) 7249 / 46 443
www.austroflamm.com
info@austroflamm.com

Redaktion: Olivera Stojanovic

Abbildungen: Konstruktion

Text: Technische Abteilung (Austroflamm)

Copyright

Alle Rechte vorbehalten. Der Inhalt dieser Anleitung darf nur mit Genehmigung des Herausgebers vervielfältigt oder verbreitet werden! Druck-, Rechtschreib- und Satzfehler vorbehalten.

Die Informationen in diesem Dokument können ohne vorherige Ankündigung geändert werden und stellen keine Verpflichtung seitens der Austroflamm GmbH dar. Für eventuelle Fehler in diesem Dokument übernimmt die Austroflamm GmbH keine Haftung.

Inhaltsverzeichnis

Deutsch.....	4
English	10
Français.....	16
Italiano	22

Inhaltsverzeichnis

1	Allgemeines.....	5
2	Konvektionsmantel montieren (45x51 K 2.0+Kr, 45x57 K 2.0, 45x68 K 2.0).....	6

1 Allgemeines

KV Mantel 361004

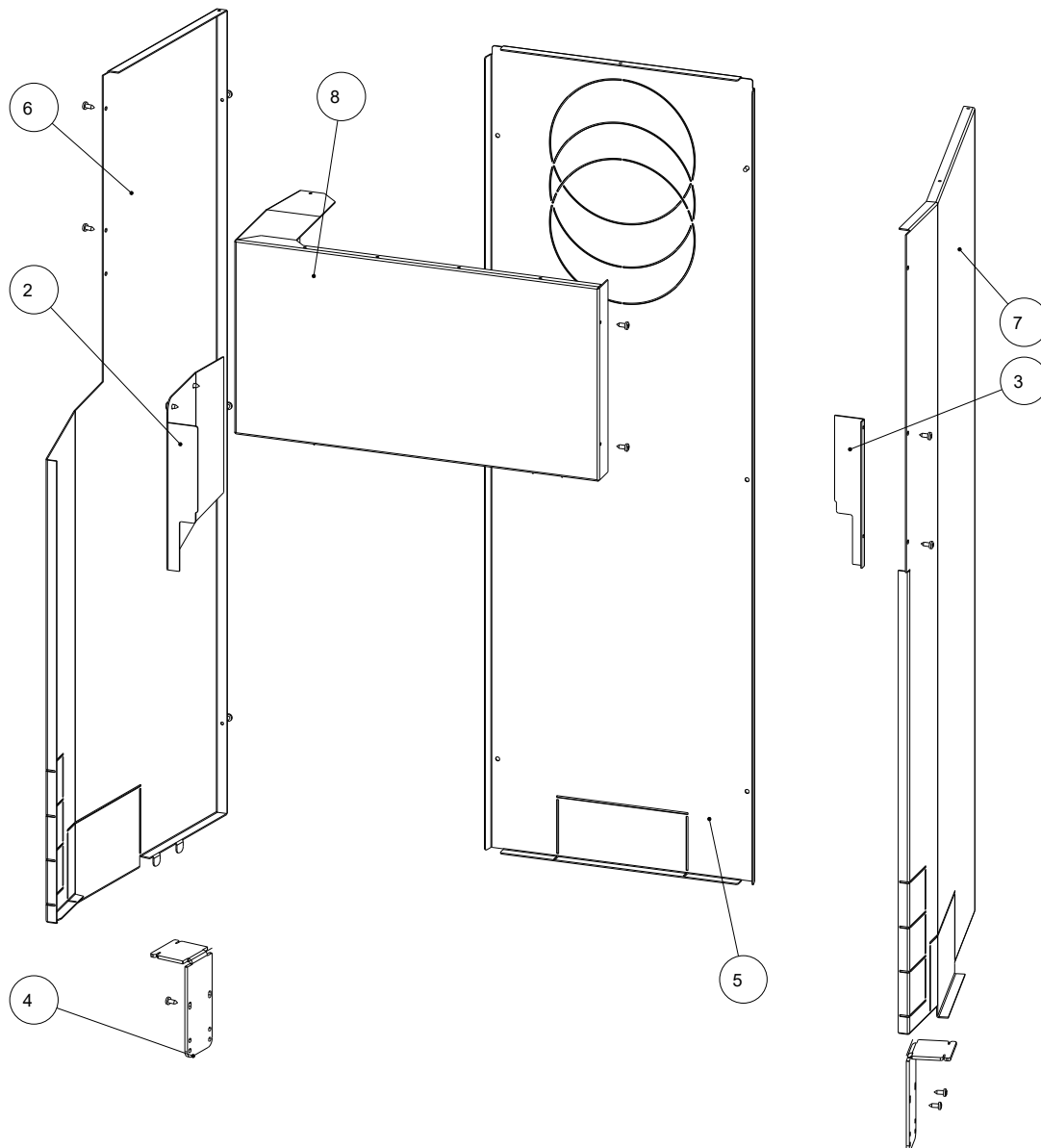
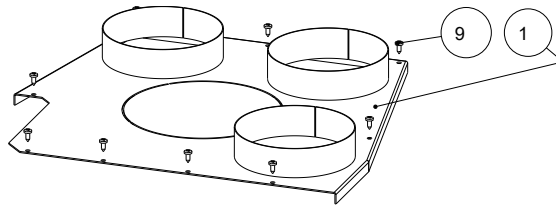

Pos.	Stück	Artikel	Artikel-Nr.
1	1	KV-Deckel	771208-95
2	1	KV-Ergänzung links	771148-95
3	1	KV-Ergänzung rechts	771153-95
4	2	KV-Mantelstütze	771147-95
5	1	KV-Wand hinten	771185-95
6	1	KV-Wand links	771186-95
7	1	KV-Wand rechts	771187-95
8	1	KV-Wand vorne	771192
9	31	Linsen-Blehschrauben mit KS 4.8x13	718247-91

2 Konvektionsmantel montieren (45x51 K 2.0+Kr, 45x57 K 2.0, 45x68 K 2.0)

HINWEIS

Bitte beachten Sie bei Verwendung eines KV-Mantels die nationalen Vorschriften bezüglich Einzelraumfeuerstätten und Messpflicht bei Ganzhaus-Heizung.



Abb. 1: Halterung links und rechts montieren

- 1) Halterung links und rechts am Kamineinsatz montieren.
 - ⇒ Beachten Sie dabei die unterschiedlichen Positionierungen dieser Halterung, für die verschiedenen Ausführungen der Kamineinsätze, in den folgenden Abbildungen.



Abb. 2: KVM x51

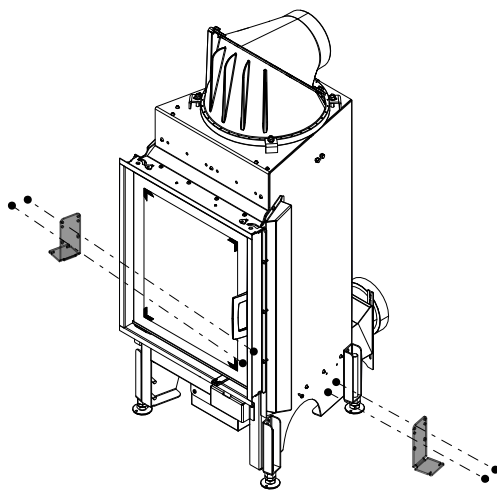

Abb. 3: KVM x57

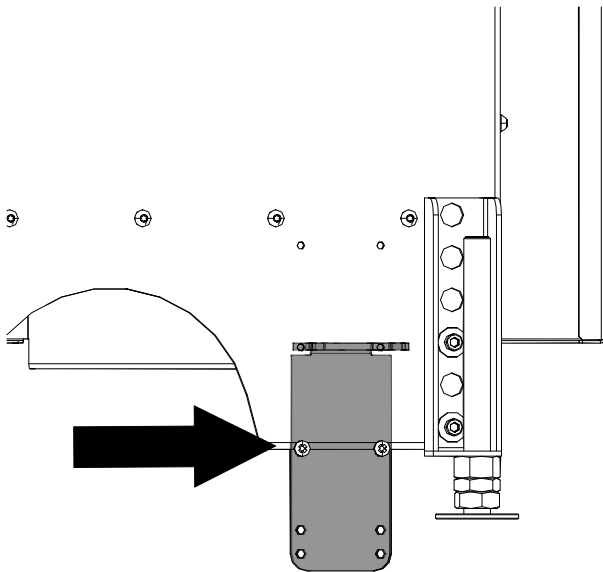

Abb. 4: KVM x68

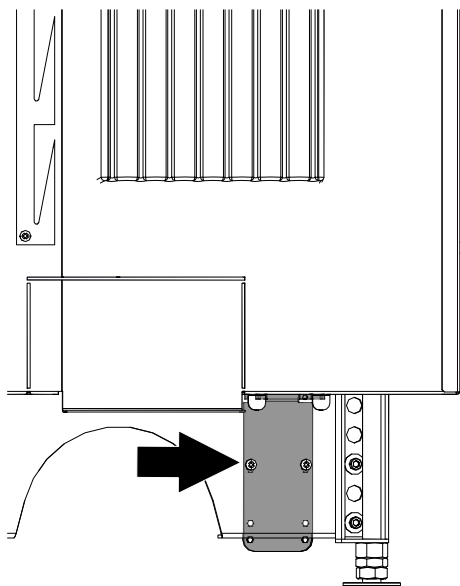

Abb. 5: KV-Wand vorne montieren

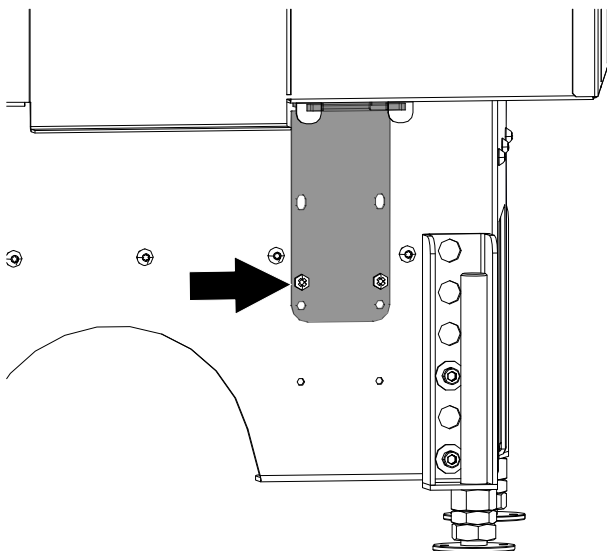

Abb. 6: KV-Deckel montieren

2) Die KV-Wand vorne montieren.

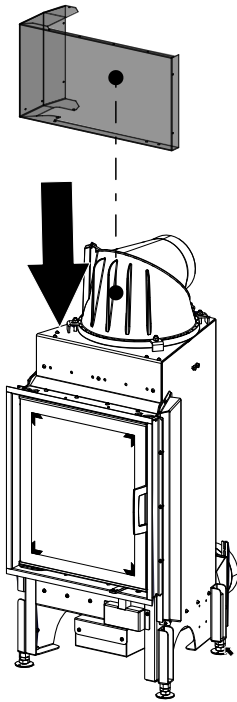
3) KV-Deckel montieren.

⇒ Falls notwendig, den perforierten Ausschnitt am Deckel mit einer Säge entfernen.

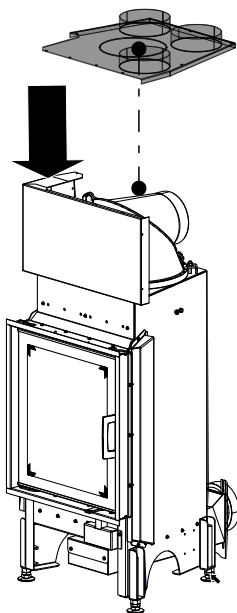
- 4) KV-Wand rechts und links an die Halterungen anbringen und einrasten.



Abb. 7: KV-Wand rechts und links anbringen



Abb. 8: KV-Wand rechts und links einrasten

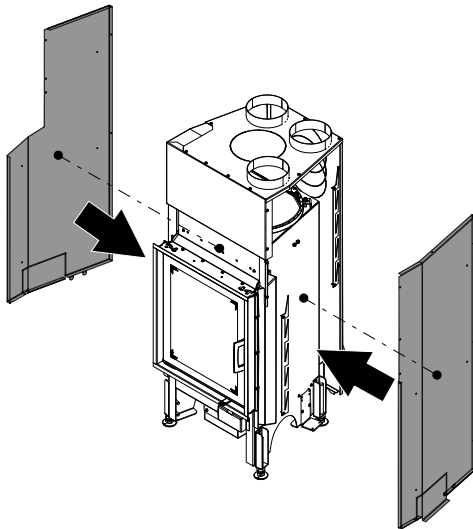

Abb. 9: KV-Wand hinten montieren

- 5) KV-Wand hinten montieren.

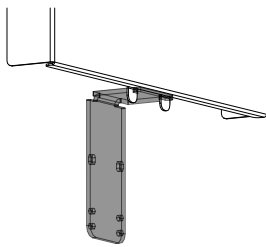

Abb. 10: KVM montiert

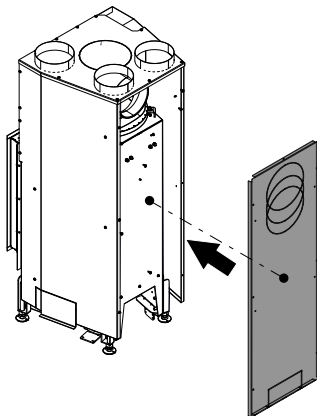
Contents

1	General.....	11
2	Mounting the convection cladding (45x51 K 2.0+Kr, 45x57 K 2.0, 45x68 K 2.0).....	12

1 General

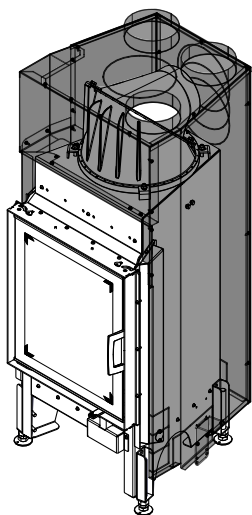
CV cladding 361004

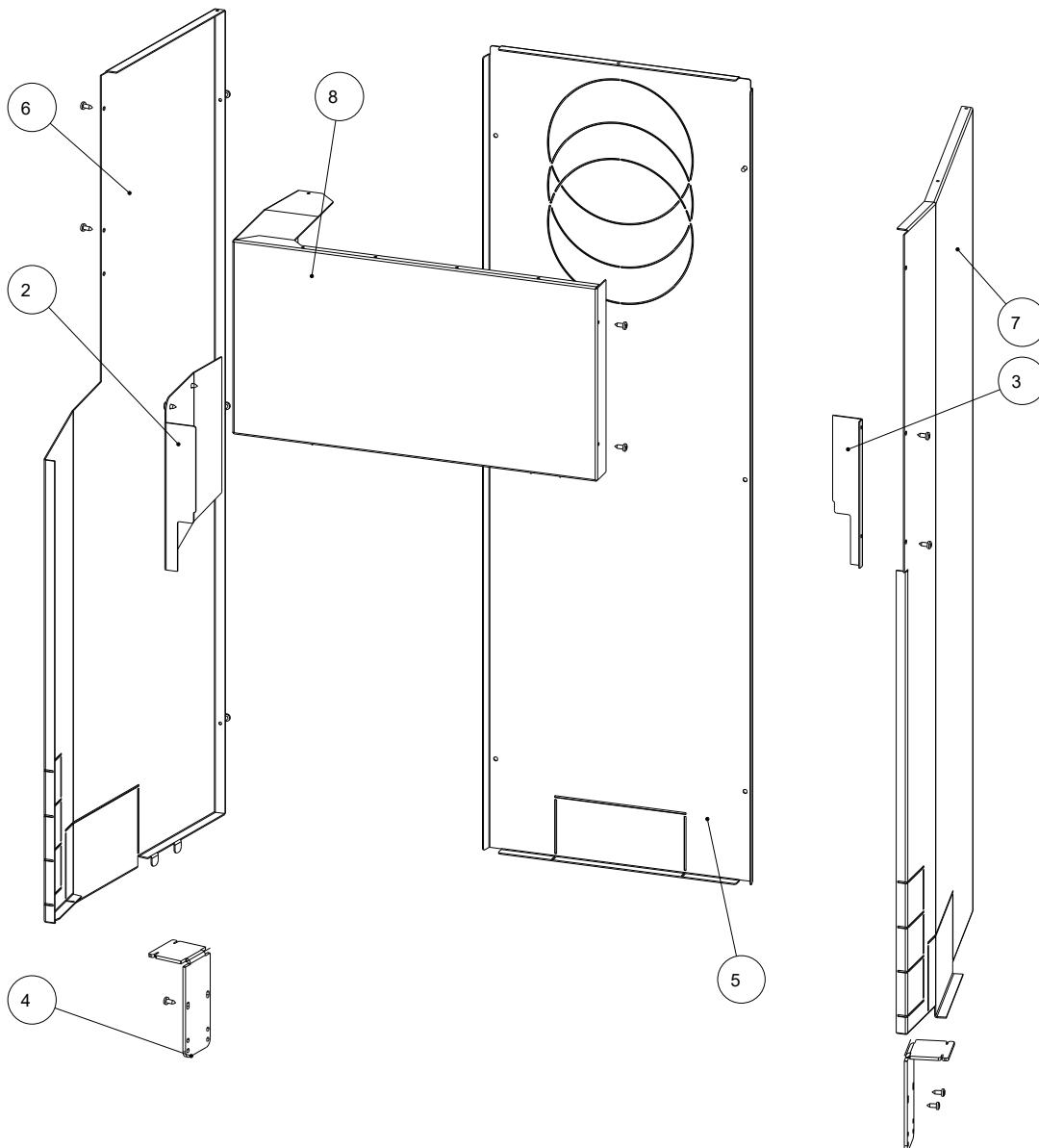
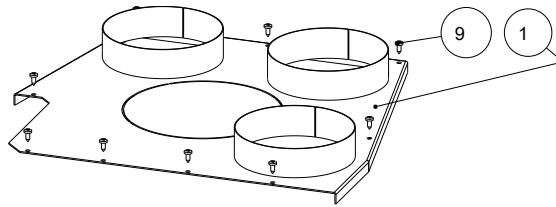

Item	Qty	Article	Article no.
1	1	CV cover	771208-95
2	1	CV extension, left	771148-95
3	1	CV extension, right	771153-95
4	2	CV cladding support	771147-95
5	1	CV panel, rear	771185-95
6	1	CV panel, left	771186-95
7	1	CV panel, right	771187-95
8	1	CV panel, front	771192
9	31	Fillister head self-tapping screws with KS 4.8x13	718247-91

2 Mounting the convection cladding (45x51 K 2.0+Kr, 45x57 K 2.0, 45x68 K 2.0)

NOTICE

When using CV cladding, please observe the national regulations in respect of individual room fireplaces and the measurement requirement in the case of whole-home heating.

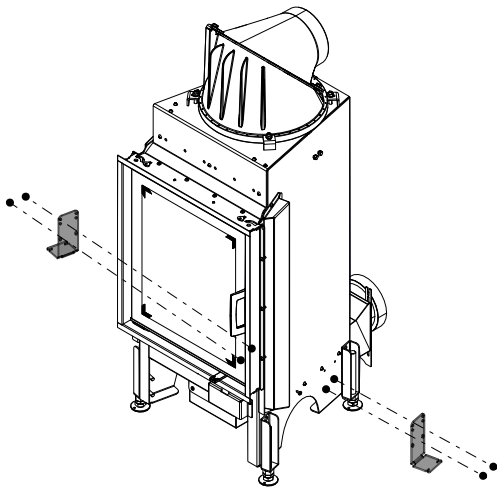

Fig. 1: Install mounting left and right

- 1) Install mounting left and right on the fireplace insert.
 - ⇒ When doing so, note the different positions of this bracket for the different versions of the fireplace inserts in the following illustrations.

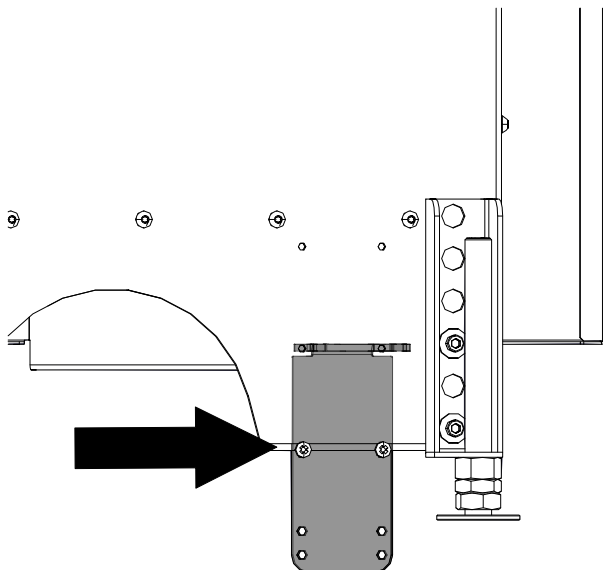

Fig. 2: CVC x51

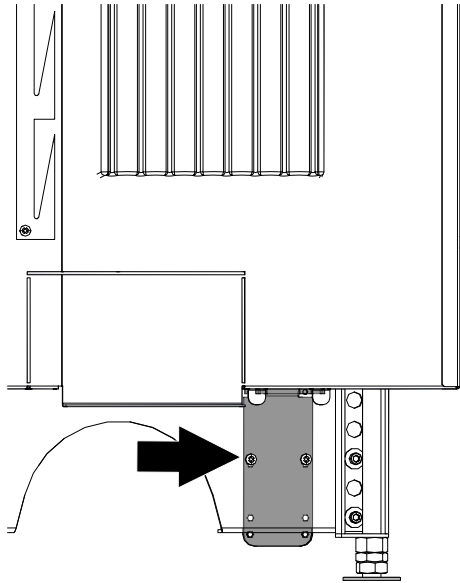

Fig. 3: CVC x57

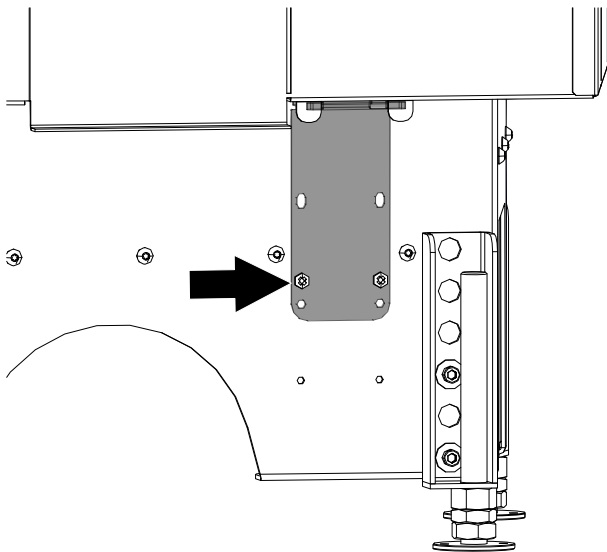

Fig. 4: CVC x68

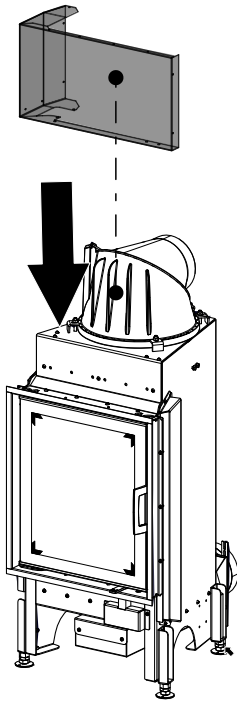

Fig. 5: Mounting the CV wall in front

2) Mount the CV wall in front.

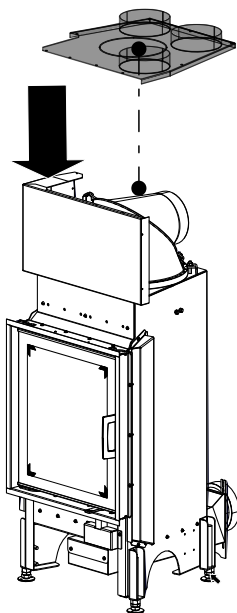

Fig. 6: Mounting the CV cover

3) Mount the CV cover.

⇒ If necessary, use a saw to remove the perforated cut-out on the cover.

- 4) Attach and engage the CV wall right and left to the mountings.

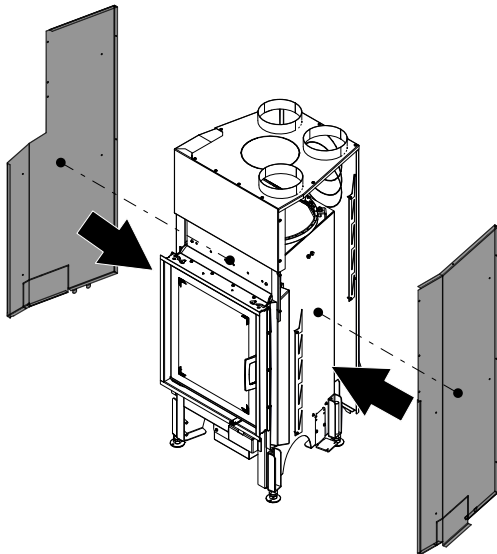

Fig. 7: Attaching CV wall right and left

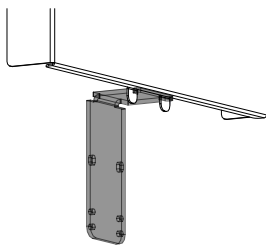

Fig. 8: Engaging CV wall right and left

- 5) Mount the CV wall at the back.

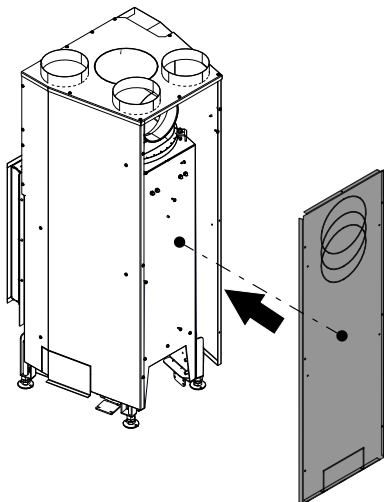

Fig. 9: Mounting the CV wall at the back

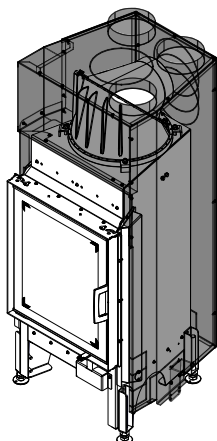

Fig. 10: CVC installed

Sommaire

1	Généralités	17
2	Installer le kit de convection (45x51 K 2.0+Kr, 45x57 K 2.0, 45x68 K 2.0).....	18

1 Généralités

Kit de convection KVM 361004

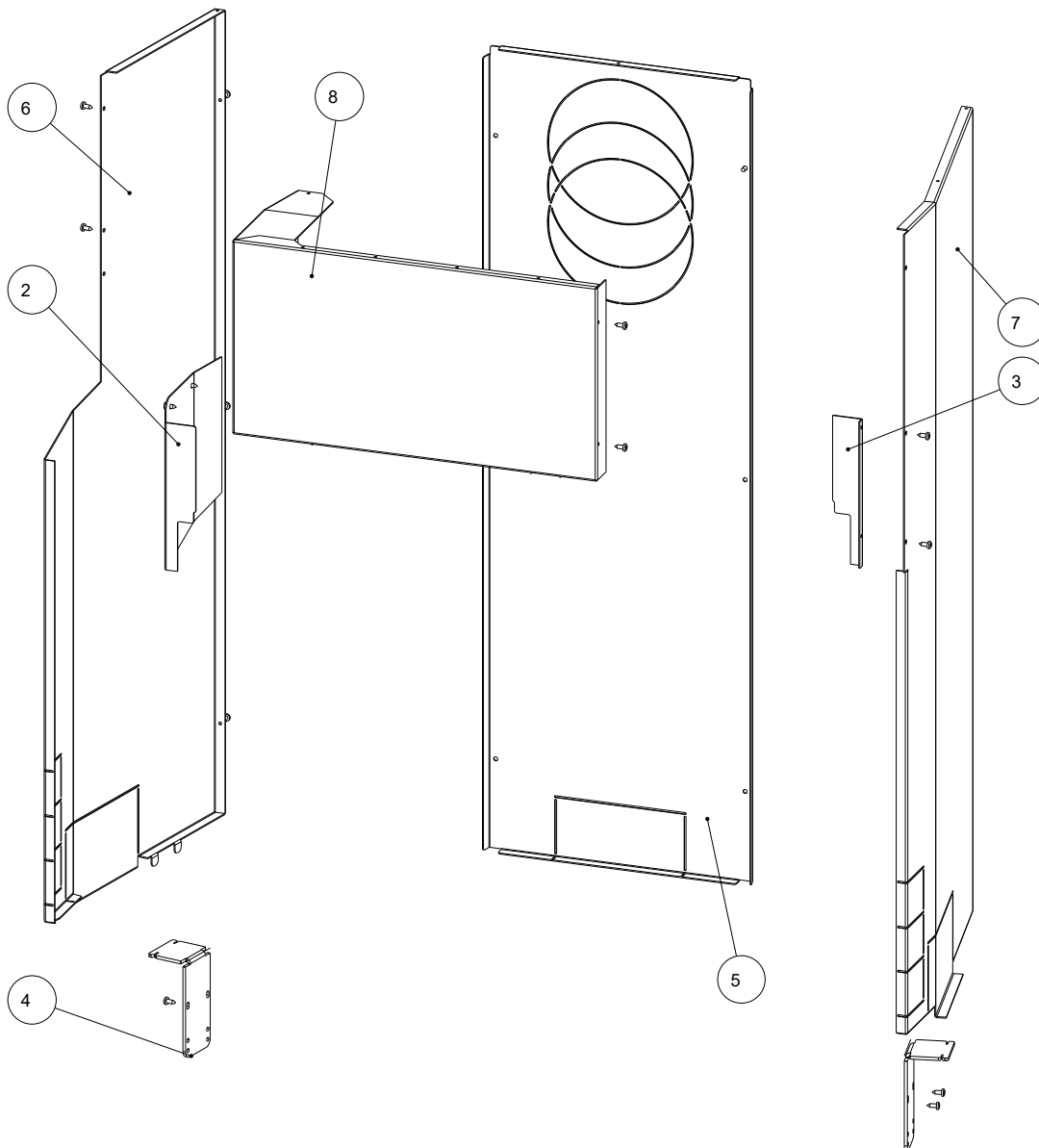
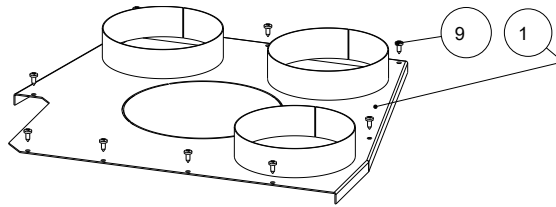

Pos.	Quantité	Article	Article n°
1	1	Couvercle de convection KVM	771208-95
2	1	Complément KVM gauche	771148-95
3	1	Complément KVM droit	771153-95
4	2	Appui pour KVM	771147-95
5	1	Paroi de convection KVM arrière	771185-95
6	1	Paroi de convection KVM gauche	771186-95
7	1	Paroi de convection KVM droite	771187-95
8	1	Paroi de convection KVM avant	771192
9	31	Vis à tôle à tête bombée cruciformes 4.8x13	718247-91

2 Installer le kit de convection (45x51 K 2.0+Kr, 45x57 K 2.0, 45x68 K 2.0)

INDICATION

En cas d'utilisation d'un kit de convection, respecter les prescriptions nationales concernant les foyers pour pièce individuelle et le devoir de mesure pour un chauffage pour toute la maison.

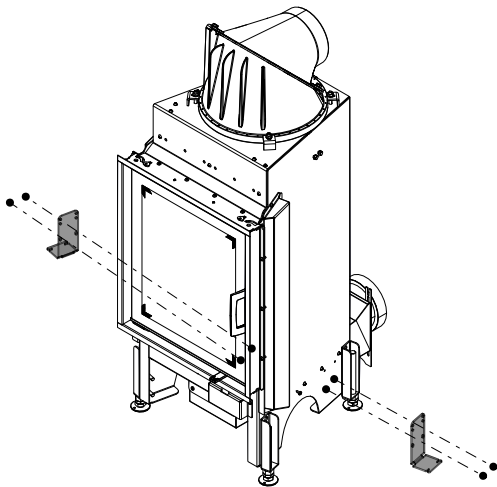

Fig. 1: Installer les fixations gauche et droite

1) Installer les fixations gauche et droite sur le foyer.

- ⇒ Respectez les différents positionnements de ces fixations indiqués dans les illustrations suivantes en fonction des différents modèles de foyers.

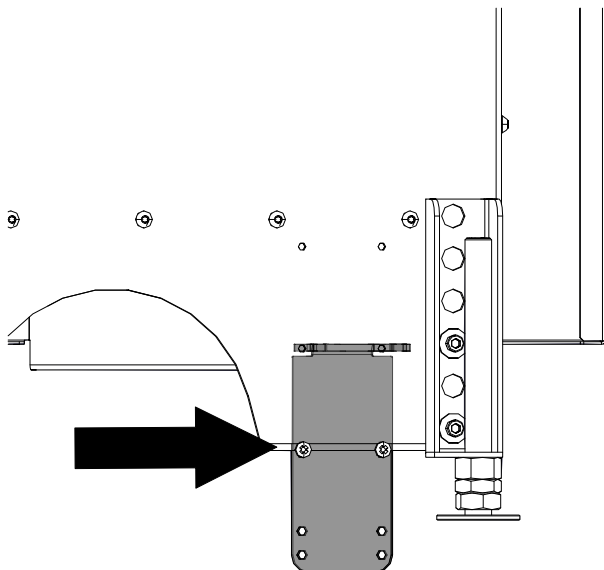

Fig. 2: KVM x51

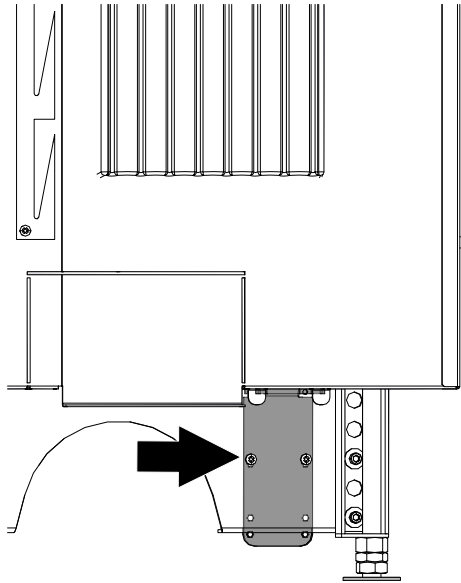

Fig. 3: KVM x57

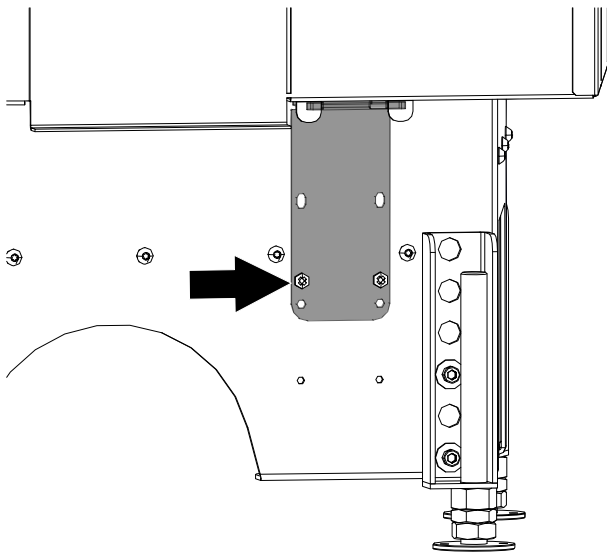

Fig. 4: KVM x68

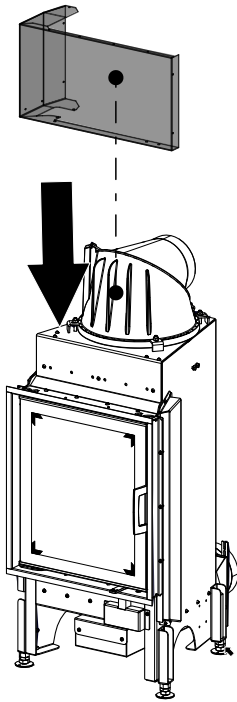

Fig. 5: Installer la paroi de convection avant

2) Installer la paroi de convection avant.

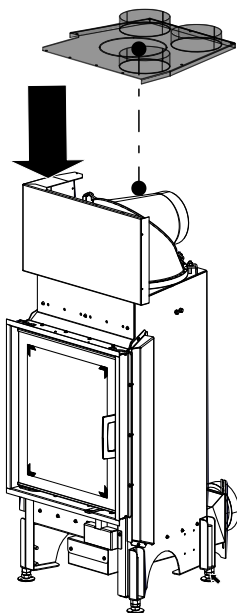

Fig. 6: Installer le couvercle de convection

3) Installer le couvercle de convection.

⇒ Si nécessaire, enlever à la scie la découpe perforée du couvercle.

- 4) Poser les parois de convection droite et gauche sur les fixations et les enclencher.

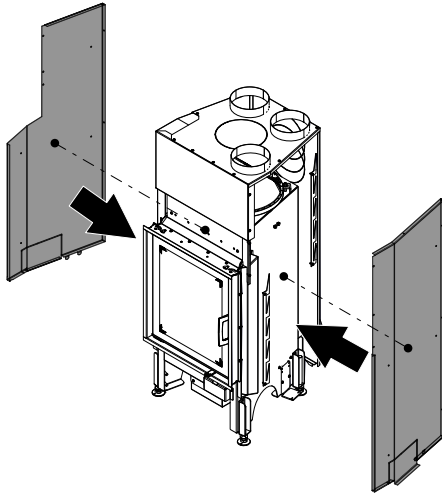

Fig. 7: Poser les parois de convection droite et gauche

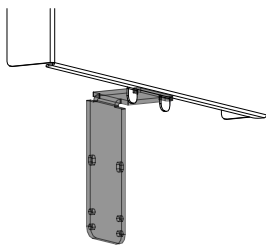

Fig. 8: Enclencher les parois de convection droite et gauche

- 5) Installer la paroi de convection arrière.

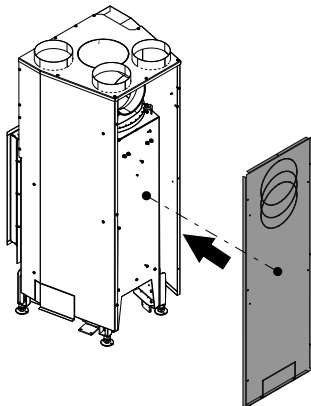

Fig. 9: Installer la paroi de convection arrière

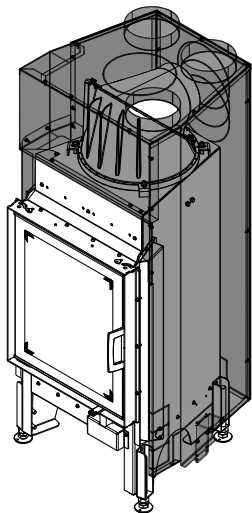

Fig. 10: KVM en place

Indice

1	Generalità	23
2	Montaggio del cappotto a convezione (45x51 K 2.0, 45x57 K 2.0, 45x68 K 2.0)	24

1 Generalità

Installazione cappotto KV 004

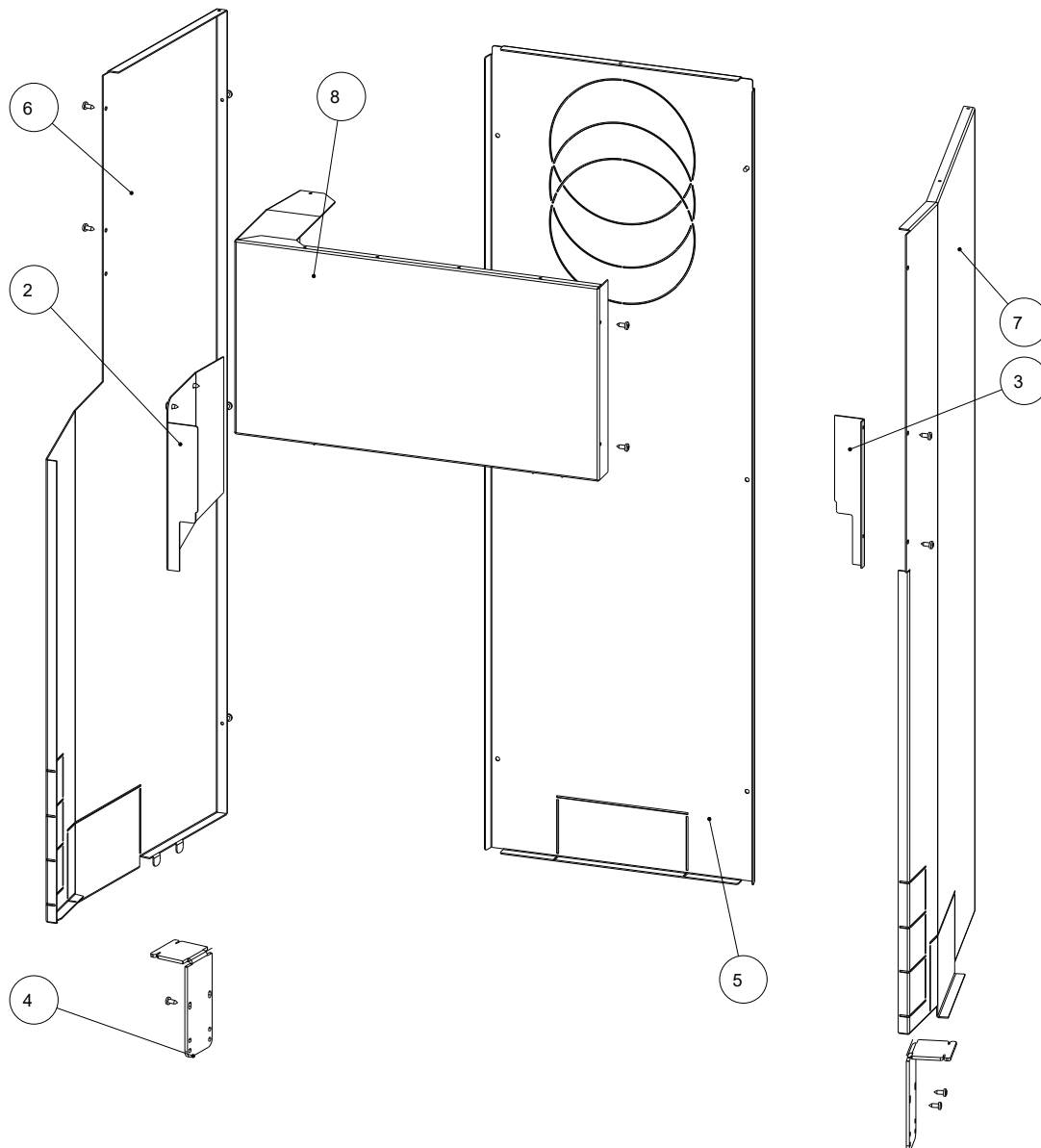
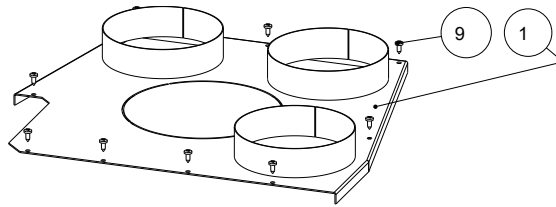

Pos.	Pz.	Articolo	N. art.
1	1	Coperchio tubo fumi	771208-95
2	1	Complemento KV sx	771148-95
3	1	Complemento KV dx	771153-95
4	2	Coppia mantello KV	771147-95
5	1	Parete post. KV	771185-95
6	1	Complemento KV sx	771186-95
7	1	parete dx KV	771187-95
8	1	Parete ant. KV	771192
9	31	Vite autofilettante a testa bombata con taglio/testa a croce 3 KS 4.8x13	718247-91

2 Montaggio del cappotto a convezione (45x51 K 2.0, 45x57 K 2.0, 45x68 K 2.0)

AVVERTENZA

Se si utilizza un cappotto KV, si prega di osservare le norme nazionali relative ai caminetti a camera singola nonché le misure obbligatorie per il riscaldamento dell'intera abitazione.

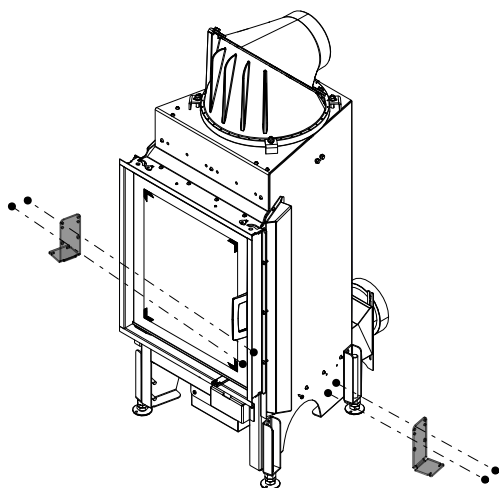

Fig. 1: Montaggio del supporto a sinistra e a destra

- 1) Montare il supporto a sinistra e a destra dell'inserto.
 - ⇒ Si prega di osservare nelle illustrazioni seguenti i diversi tipi di posizionamento di questo supporto, dovuti alle diverse versioni dei supporti per caminetto.

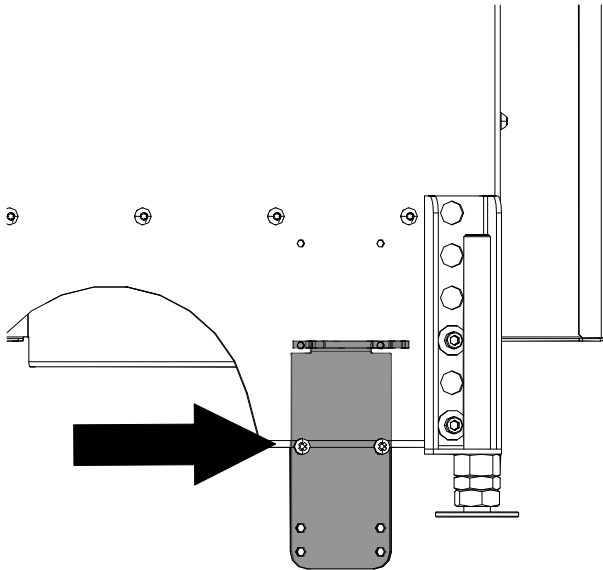

Fig. 2: KVM x51

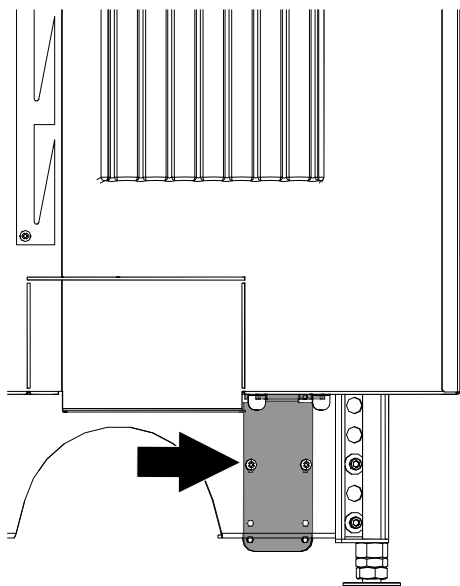

Fig. 3: KVM x57

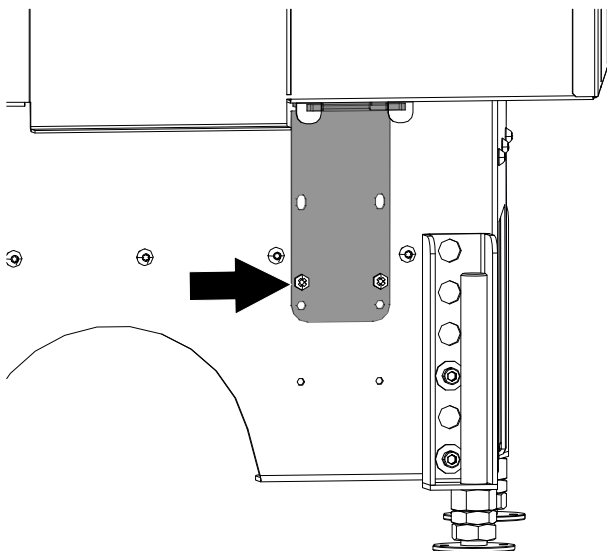

Fig. 4: KVM x68

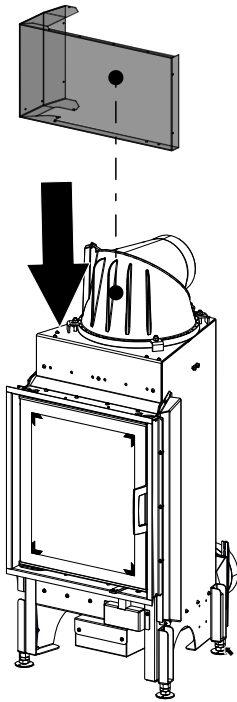

Fig. 5: Montaggio della parete KV anteriore

2) Montare la parete KV anteriore.

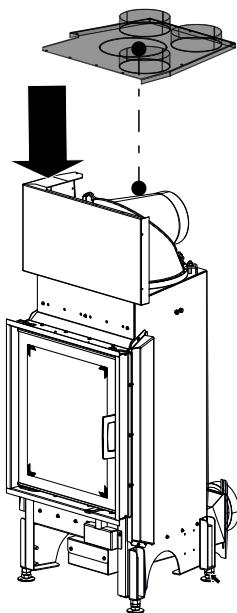

Fig. 6: Montaggio del coperchio KV (conv.)

3) Montaggio del coperchio KV (conv.).

⇒ All'occorrenza rimuovere la sezione perforata del coperchio con una sega.

- 4) Applicare e innestare la parete KV a destra e a sinistra dei supporti.

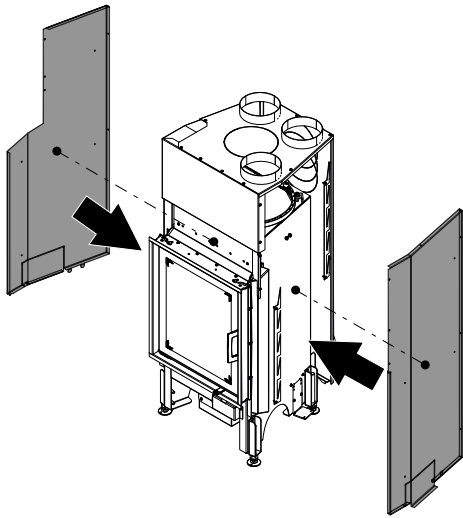

Fig. 7: Applicazione della parete KV a destra e a sinistra

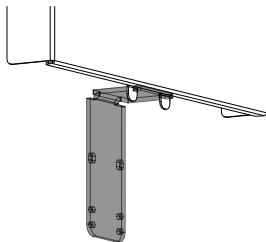

Fig. 8: Innesto della parete KV a destra e a sinistra

- 5) Montare la parete KV posteriore.

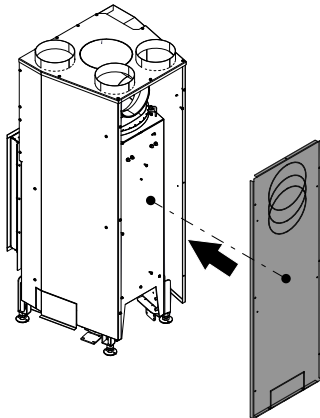

Fig. 9: Montaggio della parete KV posteriore

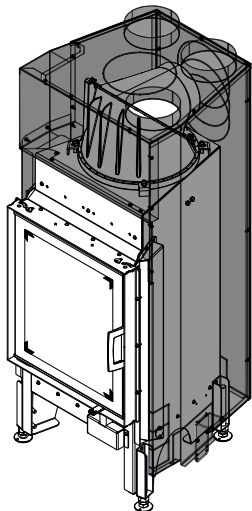

Fig. 10: KVM montato

AUSTROFLAMM GMBH
Austroflamm-Platz 1
A- 4631 Krenglbach

Tel: +43 (0) 7249 / 46 443
www.austroflamm.com
info@austroflamm.com

361004-945225

