

ELECTRIC DIAGRAM: MAIN

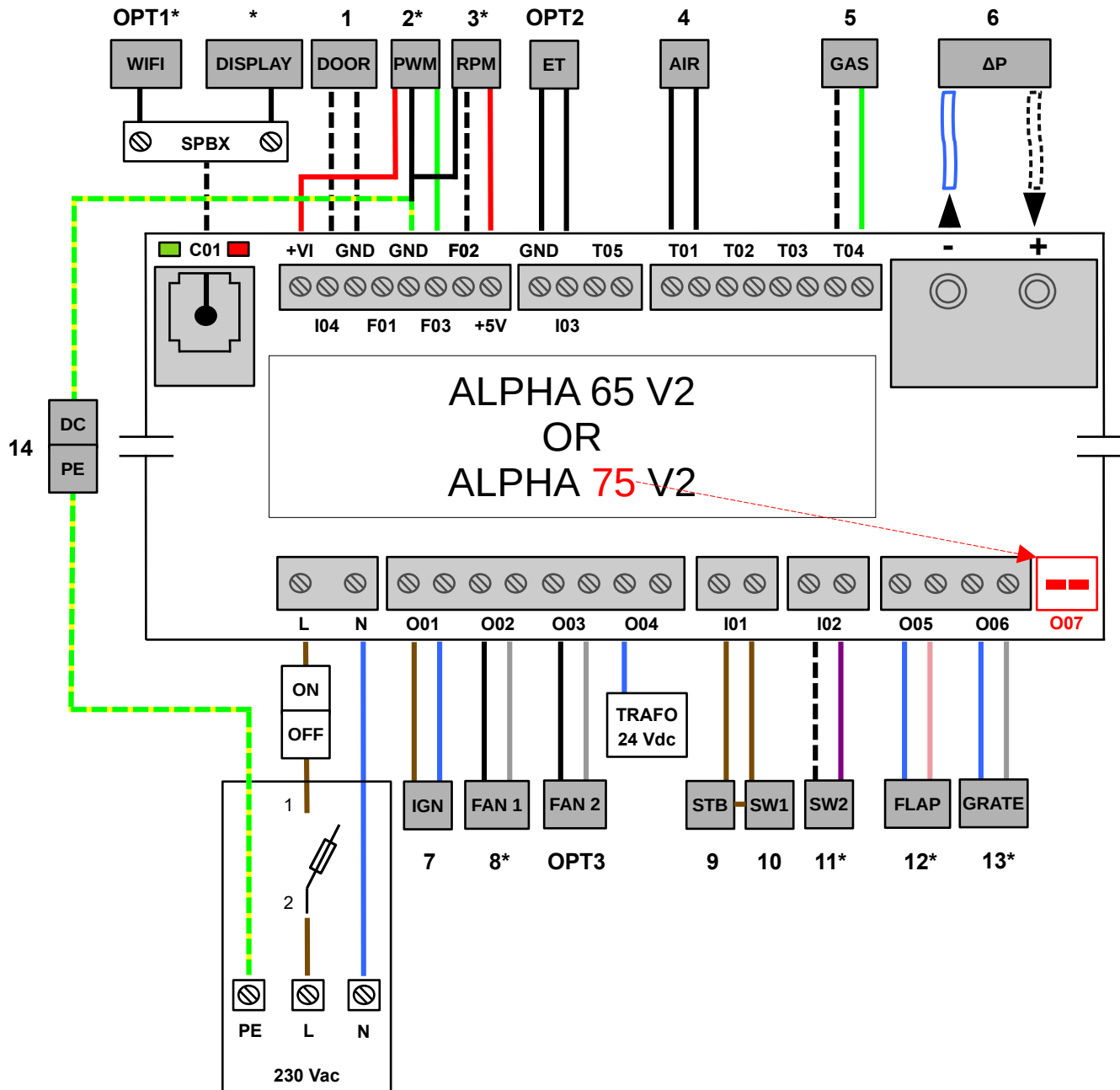

1.	Door contact switch
2.	PWM to DC Converter
3.	RPM / HAL-IC
4.	Room temperature sensor
5.	Firebox temperature sensor
6.	Differential pressure measurement
7.	Ceramic ignition
8.	Combustion fan
9.	Safety temperature limiter
10.	Hopper lid safety switch
11.	Grate position switch
12.	Air flap motor
13.	Grate motor
14	Central grounding
OPT1	WiFi
OPT2	External thermostat
OPT3	Air distribution module
*	See additional electric wiring diagrams

ELECTRIC DIAGRAM: COMBUSTION VENTILATOR

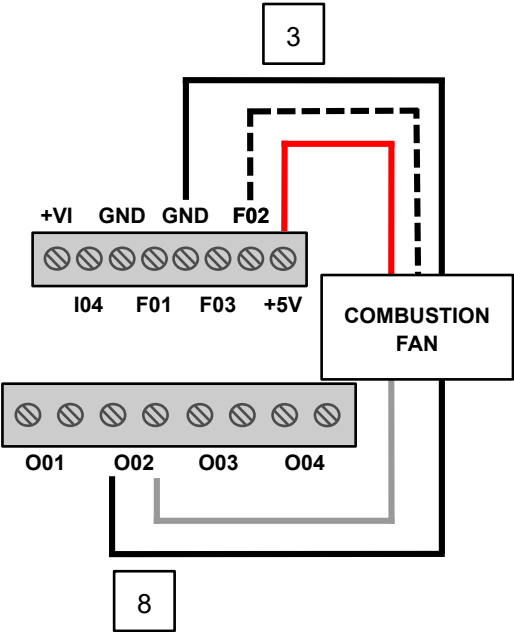

ELECTRIC DIAGRAM: FEEDER MOTOR

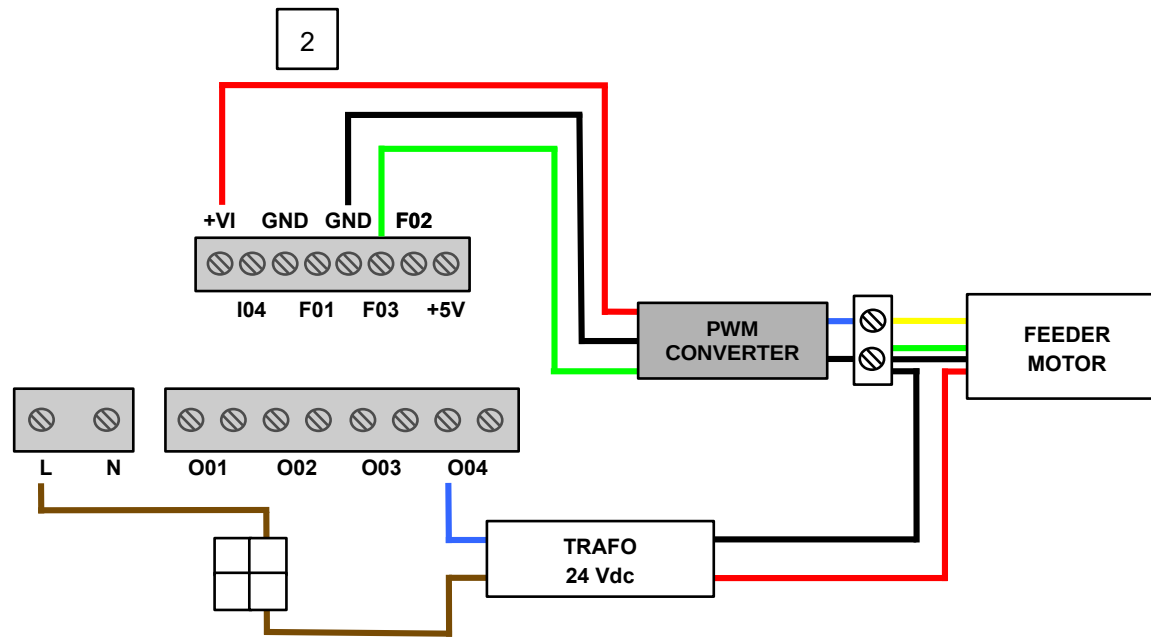

ELECTRIC DIAGRAM: AIR FLAP MOTOR

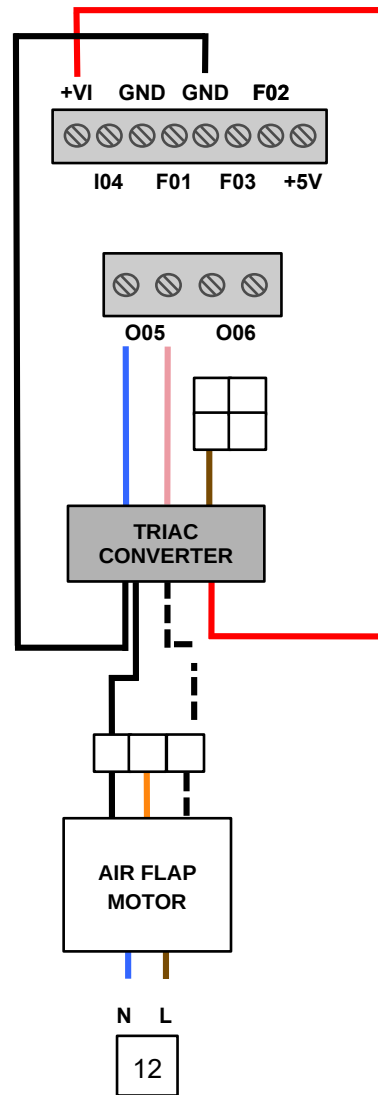

ELECTRIC DIAGRAM: GRATE MOTOR

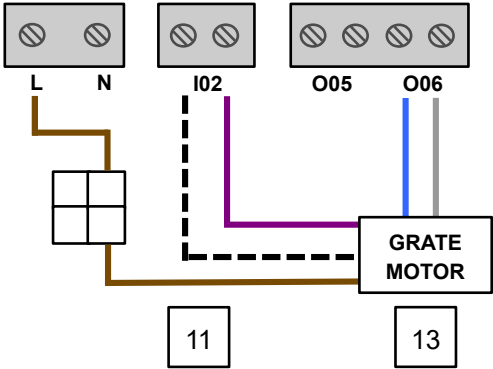

ELECTRIC DIAGRAM: COMMUNICATION SPLITTER

